



MICROWELL



Installation and user manual

POOL DEHUMIDIFIER

Model: DRY 800 METAL

DRY 1200 METAL



Version: 01/2026





Thank you, for purchasing a Microwell swimming pool dehumidifier. You have probably chosen the best and most energy efficient dehumidifier for your pool. Before you use this device, it is necessary to carefully read the entire Installation and user manual. It is not allowed to commence the heat pump installation or operation unless full content of this Installation and user manual is understood and acknowledged. Please keep the Installation and user manual available in the case of any future reference is required. Please provide this information also to each user of the device. Please

mind local regulations in your country regarding installation and usage of this heat pump which are valid in addition to this User manual.

Contents

1.	WASTE DISPOSAL INFORMATION.....	3
2.	SAFETY MEASURES.....	3
2.1	ELECTRICAL SAFETY	3
2.2	USAGE PRECAUTIONS	4
2.3	HANDLING PRECAUTIONS	5
3.	PRODUCT DESCRIPTION	6
3.1	DESCRIPTION OF BASIC PARTS.....	9
3.2	FRESH AIR SUPPLY (ON DEMAND AS ACCESSORY)	9
4.	HANDLING INSTRUCTIONS	10
4.1	TOUCH CONTROLLER	10
4.2	RS-485 AND OTHER INTERFACES (DRY CONTACT)	21
4.3	HUMIDITY CONTROL BY REMOTE CONTROLLER - ON DEMAND.....	26
4.4	HUMIDITY CONTROL BY EXTERNAL WIRED HUMIDISTAT EBERLE	28
4.5	COMPRESSOR REGULATION.....	28
5.	INSTALLATION MANUAL	29
5.1	LOCATING THE DEVICE	30
5.2	INSTALLATION OF DEVICE.....	32
5.3	CONDENSATE DRAIN.....	44
5.4	MAIN POWER SUPPLY CONNECTION.....	46
5.5	LPHW HOT WATER INSERT FOR ADDITIONAL HEATING – ON DEMAND	49
5.6	ELECTRIC HEATING	51
5.7	AIR FILTER – ON DEMAND.....	51
10	TECHNICAL DATA	55
6.1	TECHNICAL DATA CHART*	55
11	SUMMER SHUTDOWN	67
7.1	TROUBLESHOOTING – SAVE TIME AND MONEY	67
7.2	MAINTANANCE INSTRUCTIONS	68
7.3	CLEANING BY SUPERCLORING	68
7.4	OPERATION DURING CONSTRUCTION	68
7.5	MICROLIGHT+	68
12	WARRANTY CONDITIONS.....	70

1. WASTE DISPOSAL INFORMATION

If you are using the heat pump in European countries, you must follow these instructions:

DISPOSAL: Do not dispose this product as unsorted municipal waste. It is prohibited to dispose this heat pump in domestic / household waste. It is prohibited to dispose this appliance into forests or natural landscape. This could lead into local soil pollution. Collection of such waste must be treated individually.



DISPOSAL POSSIBILITIES:

1. The municipality has established a collection system where electronic waste can be disposed.
2. When buying a new product, the retailer or the manufacturer may take back the old appliance free of charge.
3. Old appliance may contain valuable resources which could be sold to scrap material dealers.
4. Disposal of packaging materials such as carton box or plastic / bubble foil can be recycled. Please use your local waste separation services.



2. SAFETY MEASURES

The device is primarily designed for use in indoor swimming pools, smaller pools, spas or saunas. Alternative use is in laundries, drying rooms or other humid areas requiring dehumidification. See the technical data table to check model suitability for a pool room and pool area.

For proper and optimal operation of this device, it is necessary to keep the air temperature in the pool hall 2 - 3 °C higher than the actual water temperature in the pool. It is also necessary to maintain the air temperature in the pool hall within the operating temperature range of the dehumidifier (specified in the Technical Data section), based on the specific selection of the operating temperature of the accessories selected for the specific equipment. Lower air temperatures outside the operating temperature range can damage the device due to freezing. Higher temperatures outside the operating temperature range may damage the unit due to overheating of the unit.

It is necessary to follow the instructions in this Installation and user manual and local regulations in your country that regulate the installation and usage of this device. Incorrect, improper or operations contradictory to this User's manual may lead to injury or property damage and will lead to loss of warranty. To prevent injury or property damage the following instructions must be followed:

2.1 Electrical safety



- The device operates at dangerous electrical current.
- Only authorized persons with particular electro-technical qualification can manipulate with unit.
- Danger of electrical shock.
- Do not exceed the required power supply.
- Do not turn a device that shows signs of possible damage such as broken packaging, broken or otherwise damaged unit's chassis or cover, smoke, smell, damaged power cord etc. on.
- **It is necessary to use appropriate Residual current circuit breaker (RCD) for connection of the dehumidifier to main power supply.**
- Do not manipulate device with wet hands.

- Do not clean device with water.
- Before cleaning the device, unplug the power cord and switch off the circuit breaker of the unit's power supply.
- Installation, service or repair must be performed by a qualified technician.
- When the device is not intended to be used for a longer time, we recommend switching the circuit breaker of the unit's power supply off.
- Unit must be installed in vertical position to avoid condensate water to enter electrical part of the unit.
- It is forbidden to install the unit close to devices that may cause electrical or frequency disturbance such as welding machines, motors or rotors, WIFI/WLAN routers or repeaters.
- It is forbidden to alter electrical installation of the device. It is also forbidden to alter any other part or functionality of the device.

2.2 Usage precautions



- Do not cover or block the intake or exhaust openings. It is forbidden to block or cover the intake or exhaust openings with clothes, towels, buckets, canoes, ceiling beams, etc.
- **Do not install or place any heating appliances close to intake grilles / louvers. It could continually overheat the dehumidifier and result in its malfunction or damage.**
- Do not climb or sit on the unit.
- Do not place any objects on the top of the unit (e.g. boxes, flower vases, etc.)
- Never push or push any objects into any hose or hole.
- Do not spray any flammable substances on the device, as this may cause a fire.
- Do not clean the device with aggressive cleaning agents, which may damage or deform the unit.
- The cover of the METAL dehumidifier model is made of three-layer anti-corrosion-protected steel, with a silver metallic or white surface color.
- Use the device only for the purpose for which it was manufactured, as described in the instruction manual. Do not use parts that are not recommended.
- Do not drink or otherwise use condensate that has been aspirated by the unit. Do not return water to the pool. Water can be contaminated with bacteria.
- Children are not allowed to operate, touch or play with the unit.
- **Children are not allowed to handle the packaging, plastic / bubble foil. Risk of suffocation!**
- **Prevent children from being injured or injured by handling the unit, its parts, or its packaging. Small parts, such as the screws can be swallowed by children and cause injury.**
- Do not leave the children in the swimming pool hall unattended.

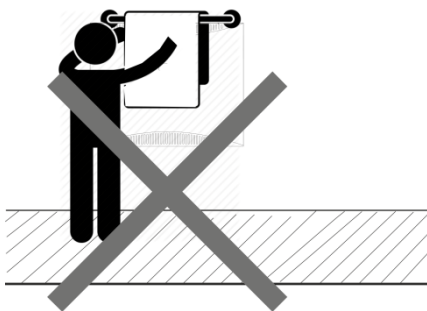

- Do not dry wet towels or swimsuits on the unit and do not put other objects on top of it (e.g. boxes, vases with flowers, etc.).

2.3 Handling precautions

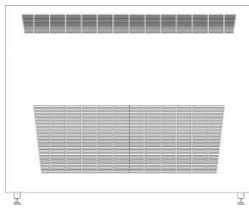
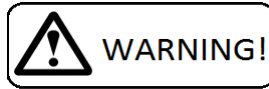

Keep in vertical position for 2 hours



Leave the unit in a vertical upright position for at least 2 hours before mounting. It is necessary to stabilize the refrigerant charge and especially to return the oil to the compressor tray. Oil could get out of the tray during transport and handling, and this could adversely affect the function of the dehumidifier.

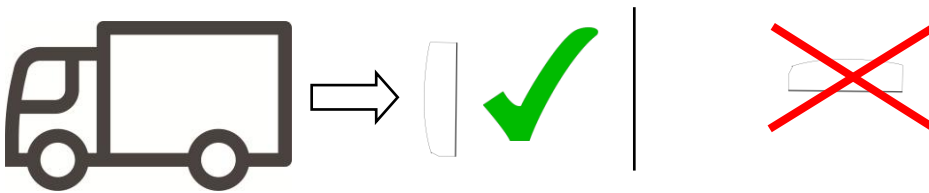

- Transport in a horizontal position or overturning the unit may damage the compressor, which may result in malfunction or damage to the unit and will void the warranty.
- The device must be handled carefully and with special care to avoid mechanical damage.

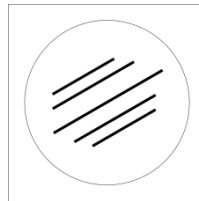
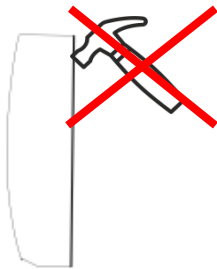

Beware of scratches. Handle the device carefully. Avoid contact with surfaces that may scratch the device.

- It is forbidden to exert any unsuitable mechanical force on the unit, which may cause mechanical damage to the device

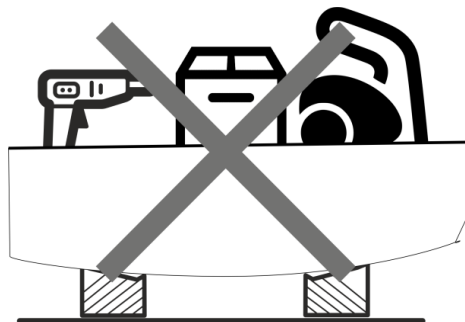

- It is forbidden to freely drop the device on the ground or any hard or rough surface that can lead to a hard impact of the device and scratch the cover. As the owner of the area make sure that your installer does not damage the cover or a part of the device during handling and installation.

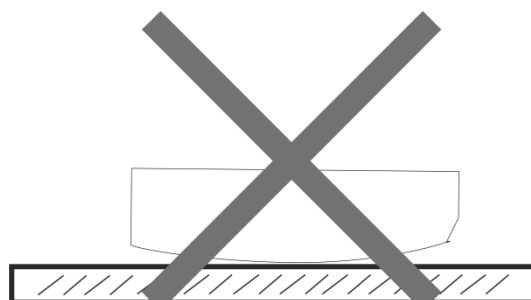
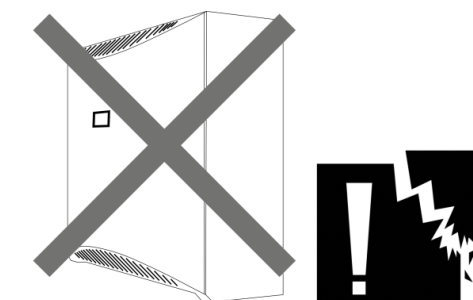

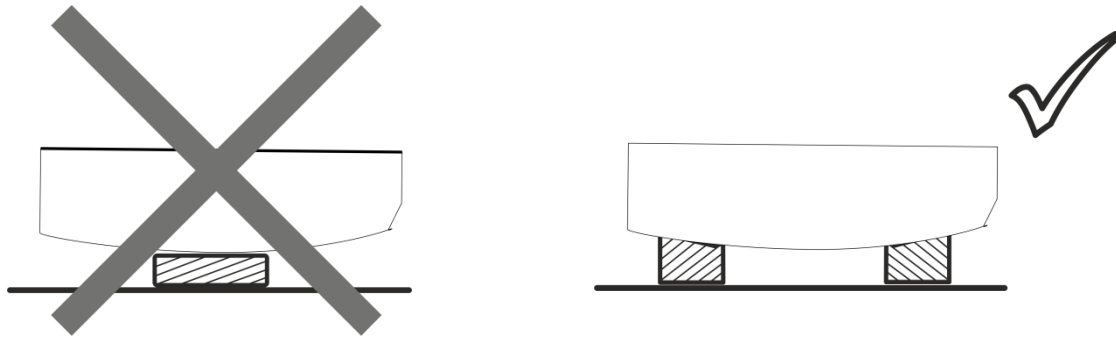



- Please notify your reseller or distributor if the delivered unit had been damaged. The unit may appear to work fine at first, but minor damage may cause the unit to stop working properly in a short time. In this case the unit must be inspected and its further use must be approved by the seller.
- Please notify your reseller or distributor if you notice immediately after installation that the unit is not working properly.
- In case of device failure resulting from improper handling or mechanical damage (impact, hit, fall, etc.), the manufacturer reserves the right to evaluate the continuity of warranty.

3. PRODUCT DESCRIPTION





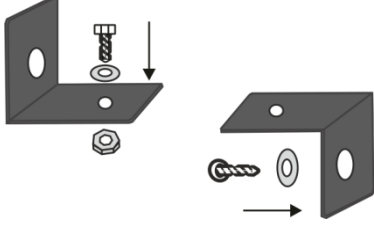

The unit was delivered in a carton box on a wooden palette. Please unpack the unit and check the content. **It should include the following:**

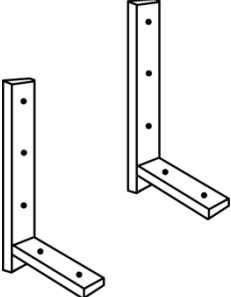

Package:

Name/ code	Image	Name/ code	Image
1 - Dehumidifier 1x		2 – Metal feet / adjustable screw with plastic heel / 4x	
3 – Condensate drain hose (illustration photo) 1x		4 - Installation and user manual 1x	







<p>5 – Adjusting "L" piece 2x</p> <p>+ screw M6 – 2x + nut MC – 1x + washer D7 – 2x</p>		<p>6- Built-in digital touch controller</p>	
--	---	--	---

Additional accessories (to order):

Name/code	Image	Name/ code	Image
<p>1 - External wireless humidistat and thermostat DRY EASY 300</p> <p>1x</p> <p>Part of packaging (white box) located on the fan plate on the left</p> <div style="border: 1px solid black; padding: 2px; width: fit-content; margin: 5px 0;">Easy300 / Eberle</div> <div style="border: 1px solid black; padding: 2px; width: fit-content; margin: 5px 0;">Solenoid valve</div>		<p>2 - External wired humidistat EBERLE</p> <p>Separate small box glued to the device (cardboard box) see picture 1</p>	
<p>3 – Wall console</p> <p>2x</p>		<p>4 – Fixing screws for a cross screwdriver D6 and dowels D10 (illustration photo)</p> <p>4x</p>	
<p>5 – Defrost thermostat</p>		<p>6 - Solenoid valve - valve and coil</p> <p>1x</p> <p>Part of packaging (white box) located under the main cover on the fan plate on the left, see. picture point. 1</p>	

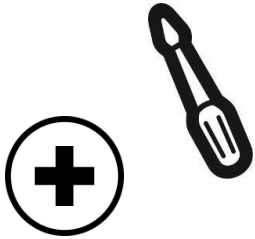
<p>7 – air filter Installed inside the device</p>		<p>8 – fresh air supply adapter</p>	
--	---	--	---

List of necessary tools (is not part of packaging):

Názov/ kód	Obrázok	Názov/ kód	Obrázok
<p>1 - Drill 1x</p>		<p>3 – Drill bit 10mm 1x</p>	
<p>2 - Phillips screwdriver 1x</p>		<p>Vacuum cleaner and ladder</p>	
<p>5 – Small hammer 1x</p>		<p>6 - Meter 1x</p>	
<p>7- Spirit level 1x</p>			

3.1 Description of basic parts

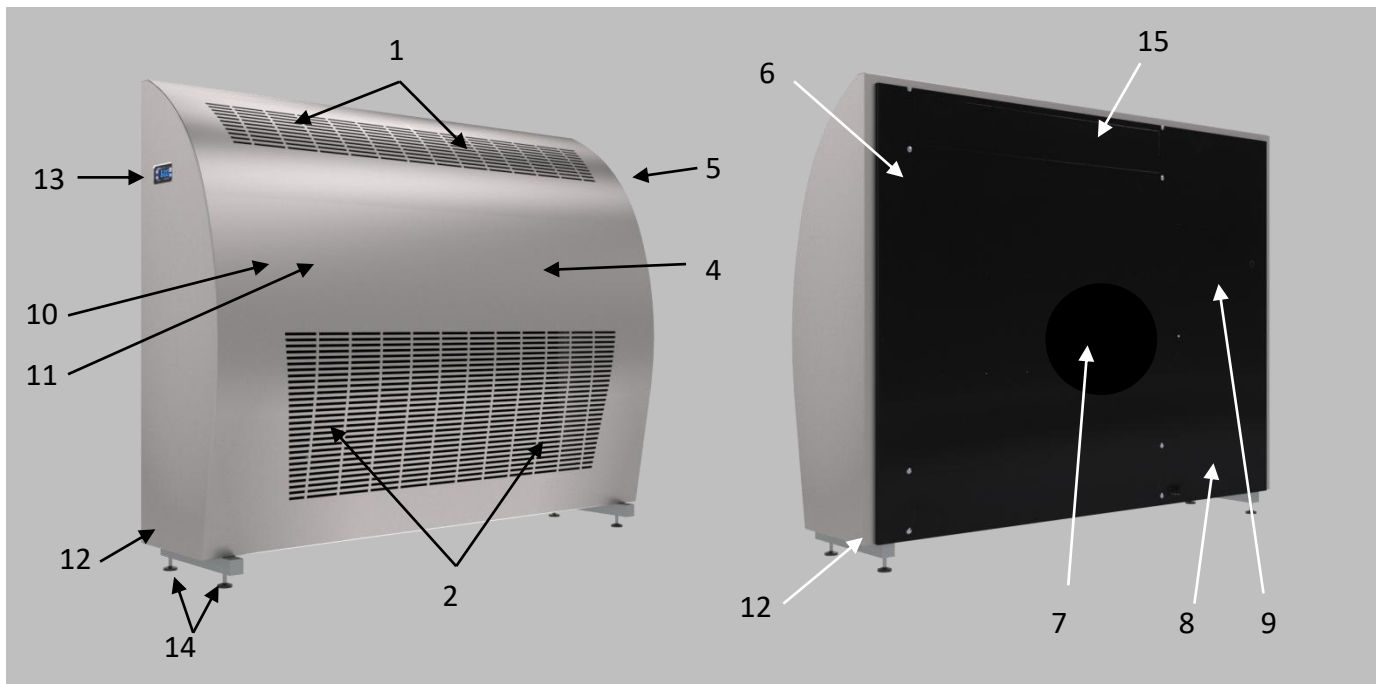

Legend:

- 1 – Air exhaust
- 2 – Air suction
- 3 – Older units: Mechanical humidistat (on the bottom)
- 4 – Metal cover
- 5 – Possible heating water supply from the right / left side ½ “(on request as accessory)
- 6 – Possible heating water supply from the back ½ “(on request as accessory)
- 7 – Fresh air supply Ø 100 mm (on request as accessory)
- 8 – Condensate drain Ø outer 20 mm (Ø inner 16 mm)
- 9 – Power supply 230 V
- 10 - position (under the cover) of the connection box for the main power supply
- 11 - position (under cover) of the fan mode switch
- 12 - position of the cover fixing screws
- 13 - Built-in digital touch controller
- 14 - Feet
- 15 - position of the nut for screwing the locking L-pieces to the wall

3.2 Fresh air supply (on demand as accessory)

Each MICROWELL DRY dehumidifier has the option of fresh air supply. The air supply is located below the condenser, which effectively heats the incoming fresh air due to heat recovery.

The metal fresh air connection is supplied already mounted on the dehumidifier, but towards the inside. When installing the dehumidifier, it is necessary to remove the flange to wind it correctly (opposite to the one supplied). For example, a plastic pipe is then mounted on the flange, which conducts the air through the wall.

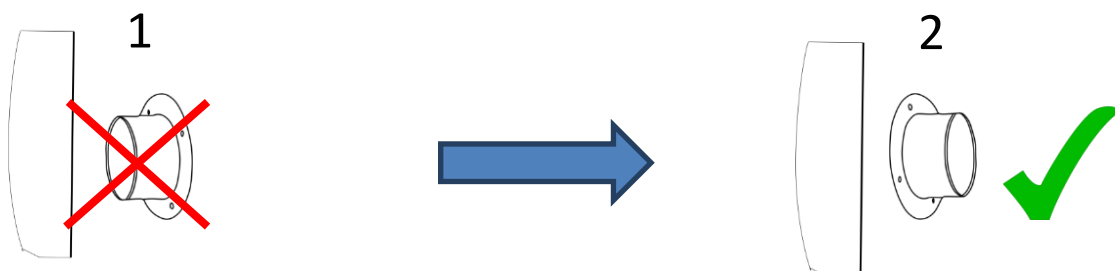

4. HANDLING INSTRUCTIONS

4.1 Touch Controller

4.2 Description of display

Please note that actual display and/or its icons may differ from the product you have.

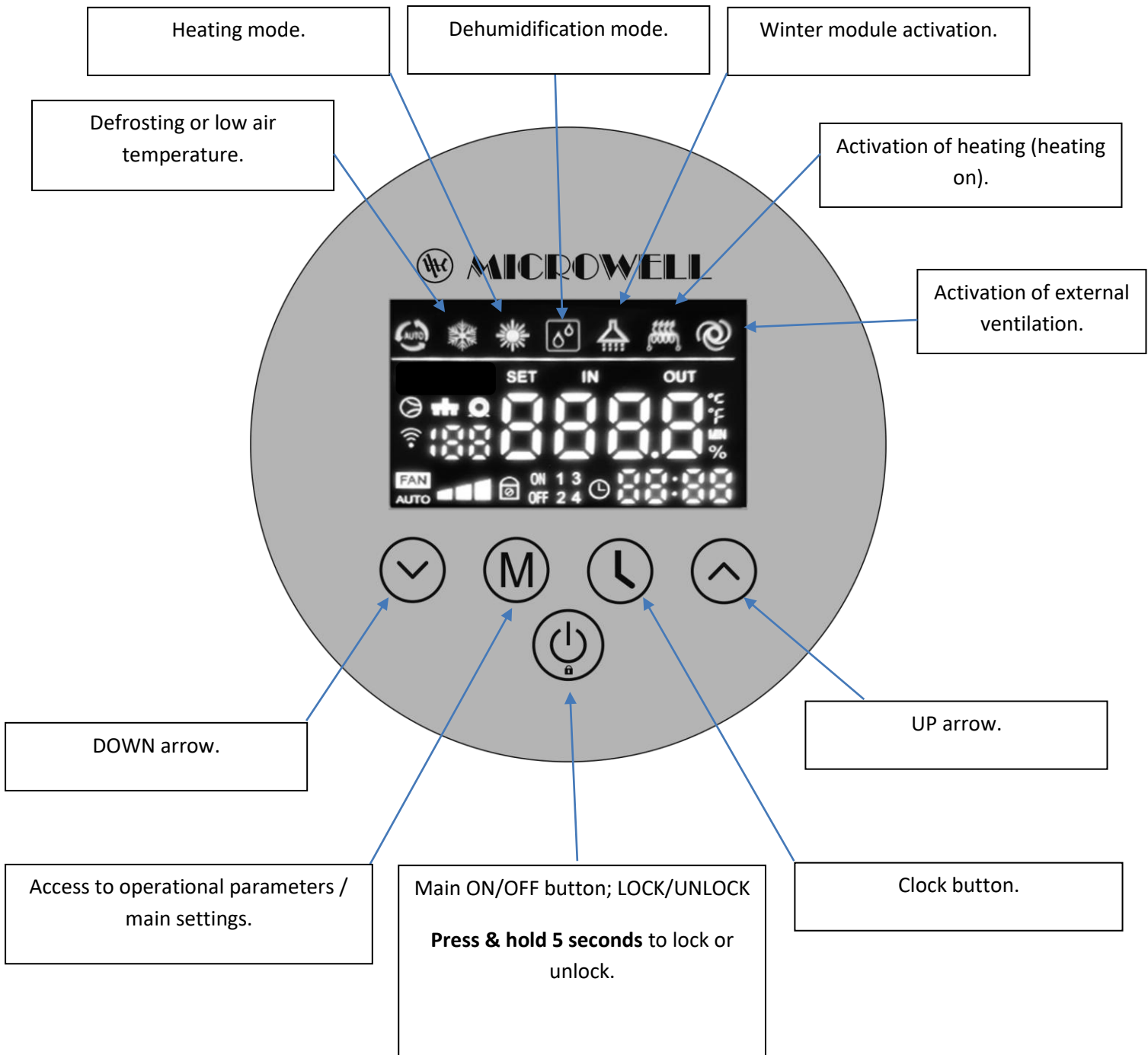

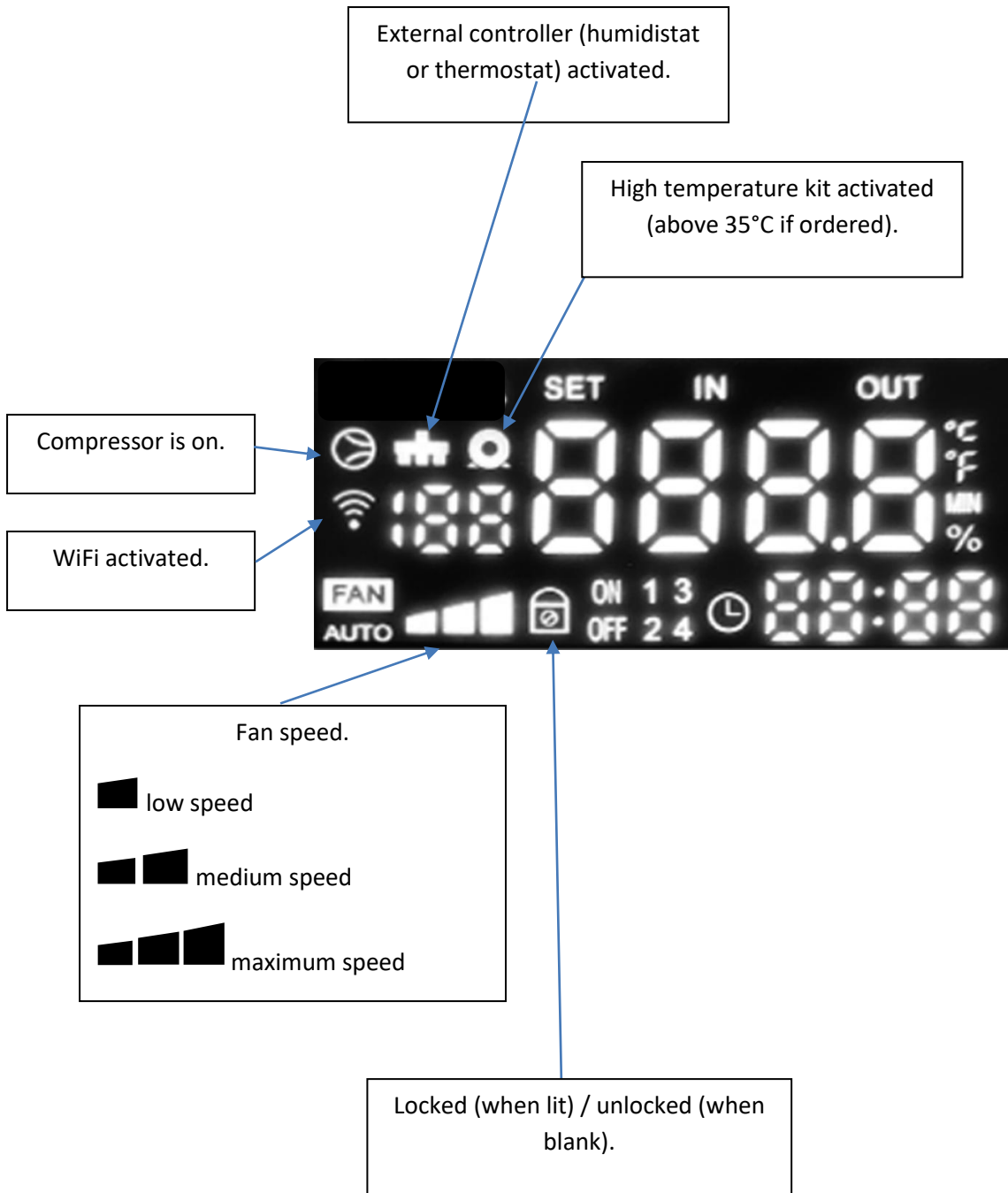

4.2.1 Humidity settings





Target humidity should be set within 50~65% RH range. Humidities lower than 40% may cause too dry environment, unnecessary electrical consumption and can cause unwilling dry feeling. Humidities above 70% create favorable environment for mold and/or bacteria growth.

Example:

Below picture shows stand-by in dehumidification mode (compressor off), current reading of relative humidity 64%, time 21:10, Wi-Fi function activated, fan on medium speed and external controller activated.



In order to set target humidity to activate dehumidification, make sure to **unlock the display** by pressing and holding the ON/OFF button  for 5 seconds. Then **set with up**  **or down**  **arrow.**



Humidity function is also dependent on hysteresis (difference between the target and actual relative humidity to activate/inactivate dehumidification). Parameter C22 is Humidity Hysteresis. Refer to its settings below in Settings (Main parameters). Hysteresis is positive (1 directional).



Should the controller be set to different than dehumidification mode then set dehumidification by pressing and holding the up arrow for 5s. You need to set the water drop icon . Make sure the display is unlocked.

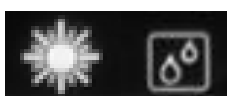

5 seconds press & hold  => .

4.2.2 Air heating settings







In order to set target air temperature to activate air heating, make sure to **unlock the display** by pressing and holding the ON/OFF button  for 5 seconds. Then press and hold M button  to access “C” System Settings (Main parameters). If you only press M button

shortly you will be prompted to self-diagnosis “d” parameters. Then proceed with arrows   to move to **C2** parameter, then press M button  to access settings of C2, then set

your requested air temperature with up  or down  arrow, confirm with M button. We suggest to keep the air temperature in range +2°C above water temperature for general pools (normally in range 26~32°C).



Air heating function is also dependent on hysteresis (difference between the target and actual air temperature to activate/inactivate air heating). Parameter C21 is Air heating Hysteresis. Refer to its settings below in Settings (Main parameters). Hysteresis is negative (1 directional).

Should the controller be set to different than dehumidification mode then set dehumidification by pressing and holding the up arrow for 5s. You need to set the sun  and water drop icon . Make sure the display is unlocked.

5 seconds press & hold  => , then again **5 seconds press & hold to show both sun and water drops **. Since the device is dehumidifier, you should keep dehumidification settings activated (water drop) and have sun activated too (to enable air heating). Please note that the actual order of symbols may differ.

4.2.3 Self-diagnosis (operational parameters)

Your controller is equipped with self-diagnosis function. This is very convenient function that enables you and your installer (dealer) to diagnose the dehumidifier based only on display readings. In most cases it allows the installer (dealer) to determine if the device is working properly and/or to identify the fault.







In order to access the self-diagnosis, make sure to **unlock the display** by pressing and holding the ON/OFF button  for 5 seconds. Then **press the M button**  **shortly (1 second)** to access “d” parameters. If you press and hold the M button for 5 seconds and more you will be prompted to “C” System parameters (settings). Press on/off to return to basic view and then tap the M shortly to access the d operational parameters.

List of self-diagnosis parameters below:

Parameter code	Sensor type	PCB connector number	Meaning of parameters	Parameter range	Sensor connector color
D1	T5 – air, 5kΩ plastic	CN3	Air temperature	-30°C~99°C	White
D2	T1 – HT sensor	CN11	Relative humidity	0%RH-99%RH	White
D3	T4 – evaporator, 5kΩ copper	CN6	Evaporator temperature	-30°C~99°C	Yellow
D4	T3 – 5kΩ copper	CN8	Suction temperature	-30°C~99°C	Black
D5	T2 – 50kΩ copper	CN9	Compressor discharge temperature	-30°C~99°C	Red
D6	-	CN3	Step number of EEV 1	0-500 steps	-
D7	-	CN4	Step number of EEV 2	0-500 steps	-
D8	-	-	Operation frequency of the DC inverter fan motor	0-2000Hz	-
D9	T6 – 50kΩ copper	CN2	Electrical heating coil temperature (if C33=1)	-30°C~99°C	

4.2.4 System Settings (main parameters)

Main settings (or parameters) mean overall core settings of your device. **Do not interfere with these settings unless you have been trained to do so.** Manufacturer, installer and/or dealer are not responsible for damages on the device, equipment and/or health risks from incorrect settings.

Your device comes with pre-set factory settings. Should you need to change the parameters, then please make sure to **unlock the display** by pressing and holding the ON/OFF button  for 5 seconds. (if you only short press M button you will be prompted to “d” self-diagnosis parameters). Then **press and hold M button**  to access “C” Settings (Main parameters). Then proceed with arrows   to move to C1-C28 parameters. In order to set particular C parameters, press M button  to access its settings. **Set with up**  **or down**  **arrow**, confirm with M button.

List of System parameters below:

C1->C9

10->28 means C10 to C28

Parameter code	Meaning of the codes	Description of parameters	Default
C1	Requested humidity	1%RH-99%RH	58%RH
C2	Requested air temperature for air heating	5°C—45°C	30°C
C3	With or without heating	0~1, 0= without heating 1= with heating	The default is 1
C4	Humidity sensor correction	-10%~10%	0%
C5	Delay detection time after the compressor starts Minimal compressor running before defrosting	20~90min	40
C6	The temperature at which the system enters the defrost point (self diagnosis d3)	-10°C~10°C	-2
C7	Temperature at which the system exits the defrosting point	0°C~15°C	8
C8	Maximum defrosting time	2min~12min	10
C9	Fan control mode	0-2 0=periodical	2





		1=continual 2=smart – air sampling for 60s after time based on parameter C24	
C 10	The return difference when the EEV exits after entering the permissible discharge temperature	1~30°C	10°C
C 11	The permissible discharge temperature when adjusted by the EEV	80°C~150°C	95°C
C 12	Operation period of the EEV.	20s~90s	30s
C 13	Target super heat.	-10~10°C	5°C
C 14	The minimum opening EEV settings	1~240	75
C 15	Fan type selection	0-AC ; 1-DC	0
C 16	High wind speed of DC motor	400-1500	1500
C 17	Low wind speed of DC motor	400-1500	600
C 18	High pressure detection function (this is refrigerant system core protection, do NOT set „0“for parameter C18 unless you have been clearly instructed by your installer or dealer to do so). Settings „0“is used to enable the device to start and read out self-diagnosis even though high-pressure protection has been engaged – error E4.	0-without ; 1-with	1 (set to “0” only for self-diagnosis purposes after you have experienced E4 error code)
C 19	Low pressure detection function (this is refrigerant system core protection, do NOT set „0“for parameter C19 unless you have been clearly instructed by your installer or dealer to do so). Settings „0“is used to enable the device to start and read out self-diagnosis even though low-pressure protection has been engaged – error E5.	0-without ; 1-with	1 (set to “0” only for self-diagnosis purposes after you have experienced E5 error code)
C 20	Return air temperature function	0-without ; 1-with	1
C 21	Air heating hysteresis Negative hysteresis – turns on when actual air temperature is	0~+10°C	1



	less than (C2-C21), turns off at C2.		
C 22	Air humidity hysteresis Positive hysteresis – turns on when actual RH is more than (target humidity+C22), turn off at target humidity.	0-10%; 0-1-2-3-4-5-...10	4
C 23	Air temperature sensor correction This parameter is to be used when you need to adjust the air temperature sensor reading.	-5~+5	0
C 24	Air sampling (periodic air measurement with „low fan speed“), 60 seconds	10-60minutes, step by 10minutes (10-20-30-40-50-60)	20
C 25	Active / Passive defrosting Attention to user: do not set „1“ yourself, there is risk of frost with subsequent damage of your dehumidifier. Settings of “1” is only used when your dehumidifier is equipped with 4-way valve (low temperature kit for air operations from +5°C).	0~1 0 = passive = 14~45°C (air flow defrosting) 1 = active = 9~45°C (only with 4-way valve)	0
C 26	Fan speed control Your dehumidifier is equipped with simulated step inverter fan. This allows the fan to assume lower speed if the air temperature and humidity and/or air heating function enables it. Typically, if RH and/or Air temperature are less than 5% (5°C) from target then if air temperature is below C26, the fan will automatically assume lower speed.	5-45	27
C 27	Temperature at which the system exits the defrosting point PASSIVE defrosting (C25=0)	0°C~20°C	15
C 28	Maximum defrosting time PASSIVE defrosting (C25=0)	2min~25min	15
C29	Ventilation	0-1	0
C30	DUCT unit	0-1	0
C31	Phase Sequence Protection /	0-1	0

	Electrical Protection IN1		
C32	Dry Contact/PV Ready IN2	0-1	0
C33	Electric heater	0-1	0
C34	LED microLIGHT	0-1	0
C35	Medium wind speed of DC motor	400-1500	900
C36	DC fan quantity	0-1 0 = single fan 1 = two fans	0

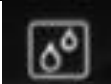
4.2.5 Description of general function

Your dehumidifier is able to maintain following function modes:

Mode	Range of the ambient temperature		Display settings in abnormal mode (including downtime due to failure)	Symbol
	5°C-45°C	Outside the range of 5°C-45°C		
Dehumidification mode	Normal dehumidification	The dehumidification mode is off, the compressor is off, and the fan is off	The dehumidification mode icon keeps flashing	
Independent heating mode	Normal heating	Normal heating	In heating mode, the icon flashes continuously	
Dehumidification and heating mode	Normal dehumidification and normal heating	The dehumidification mode is turned off. The compressor is turned off, but the fan remains on for independent heating	The icon of dehumidification plus heating mode keeps flashing	 
Air supply mode	Normal output	Normal output		

Display flashes water drops  and snowflake  => unit is defrosting.

Display shows OFF  and OUT  => DRY contact is disconnected (PV ready disabled).

The dehumidifier is programmed for automatic operations. This means that the dehumidification, air heating and ventilation (fresh air) is turned on based on requested target relative humidity and target air temperature. The fan is programmed to automatically adjust

its speed from low to high speed based on demand. If the relative humidity is within 5% (percentage points) difference from target and air temperature is below settings C27, the fan will not assume high speed. After the system has turned off active dehumidification or air heating, the fan will continue to work on medium speed to dry out or cool down the system for another 120 seconds.

- **Real-time clock setting:**

On the main interface, press “Clock” to enter the real-time clock setting screen.

On the real-time Clock screen, press the “Clock”  key, and the digit in the hour part blinks. Press the “+” key or the “-” key to set the hour of the real-time clock.

After the hours part is set, press the “Clock” key again, and the number in the minutes part blinks. Press the “+” key or the “-” key to set the minutes of the real-time clock.

After the minute part is set, press the “Clock” key again to confirm the real-time clock setting and return to the main interface.

If no key is pressed for 30 seconds on the real-time Clock setting screen, the system confirms the current real-time clock setting value and returns to the main interface.

On the real-time Clock setting screen, press the “on/off” key to confirm the current real-time clock setting and return back to the main interface.

- **Set the timer to on/off:**

On the main interface, press and hold the “Clock” key for 5 seconds to enter the screen for setting the timer group.

At this time, press the “+” key or “-” key to set the timer group, 1, 2, 3 and 4.

When segment 1 is blinking, press the “Clock” key to enter the screen for setting the hour part of the timer startup time for timer group 1. When the number of the hour part of the timer startup time is blinking, press the “+” key or the “-” key to set the timer hour section for timer group 1.

After the hour part is set and you press the “Clock” key, the number in the minute part of the timer startup time blinks. Press the “+” key or the “-” key to set the timer startup minutes. Then you can set the timer of 1 group of startup minutes.

After setting the timer of the minute section for starting group 1, press the "Clock" key to enter the hour setting for shutting down of timer group 1. The setting method is the same as the above.

After the scheduled shutdown time is set, press the "Clock" key to confirm the current set timer on/off time, enter the on/off setting of timer group 2, the setting is the same as timer group 1, and return to the main screen.



On the timer setting screen, hold down the Clock key for 5 seconds to disable the timer on/off.

On the timer interface, if no button is pressed for 30 seconds, confirm the current timer time and return to the main screen. (Power off after timing can be remembered).

On the timer interface, press the “on/off” key to confirm the current timer time and return to the main screen.

The timer settings for other segments are the same as those for segment 1.

4.2.6 Wi-Fi

Press and hold CLOCK + UPPER ARROW for 5 seconds  to enter WIFI pairing. Then the WIFI icon will flash. 

Application is Smart Life 

Open the Smart Life APP and log in to the home screen. Tap “+” in the upper right corner or “Add Device” on the screen to enter the device type selection. Select “Other” from “Other device” to enter the screen for adding device

4.2 RS-485 and other interfaces (DRY contact)

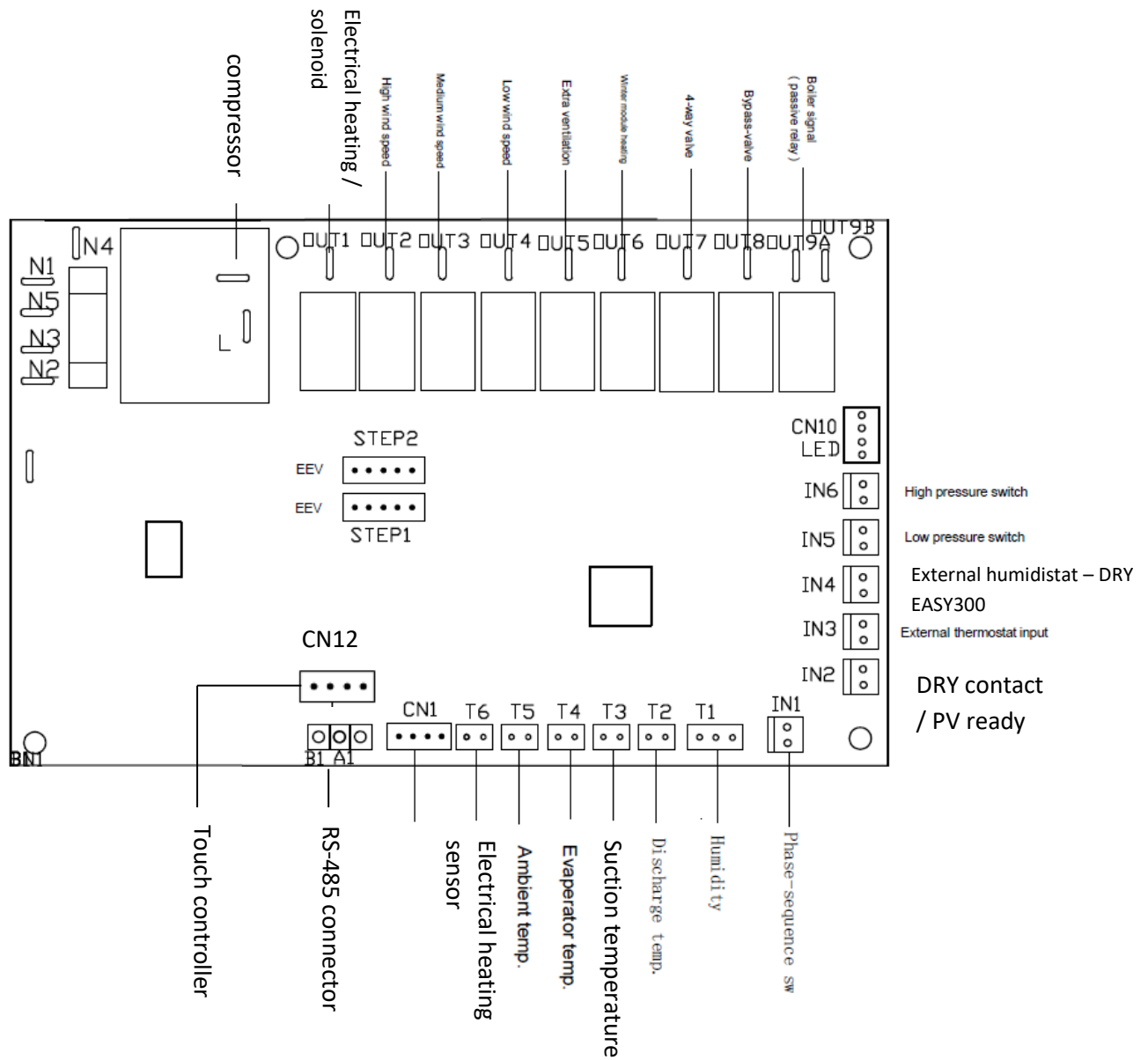

IN4 = DRY EASY300, EBERLE HYG6001 /0V

IN3 = DRY EASY300

IN2 = DRY contact, PV ready, other master control /0V

IN1 = phase sequence protection / electrical heater protection

OUT5 = external ventilation (fresh air connection) / 230V

OUT1 = Electrical heating or Solenoid valve for water heating / 230V

CN1 = External controller touch Wi-Fi

4.2.7 Error codes

Error code	Operational status of the dehumidifier	Protection/Failure description	Solution	Recoverable
E1	<p>Air heating function is disabled. Compressor and dehumidification function remains.</p> <p>In the case of E1 and closed IN3 (external thermostat) the heating and fan must remain too. E1 on display OK.</p>	Indoor temperature sensor error	Check the CN3 white connector sensor and/or exchange it.	yes
E2	<p>Air heating function works normally. Dehumidification works normally with periodic defrosting and E2 error showed.</p>	Evaporator temperature sensor error	Check the CN6 yellow connector sensor and/or exchange it.	yes
E3	<p>Air heating function works normally. Dehumidification is disabled.</p>	Humidity sensor error	Check the CN11 white connector sensor and/or exchange it.	yes
E4	<p>Dehumidification function is disabled. Serious error. This error is non-recoverable and requires manual intervention.</p> <p>Air heating function works normally.</p>	High pressure protection	<p>Restart your device with ON/OFF button, if E4 happens repeatedly, pls contact your installer or dealer.</p> <p>You may disable the high-pressure protection by setting parameter C18 to 0. This allows you to run the device and read out operational parameters to confirm or deny the error.</p>	no
E5	<p>Dehumidification function is disabled. Serious error. This error is non-recoverable and requires manual</p>	Low pressure protection	<p>Restart your device with ON/OFF button, if E5 happens repeatedly, pls contact your installer or dealer.</p> <p>You may disable the high-pressure protection by</p>	no

	<p>intervention.</p> <p>Air heating function works normally.</p>		<p>setting parameter C19 to 0. This allows you to run the device and read out operational parameters to confirm or deny the error. Low pressure error may also occur in low air temperatures. The system is programmed to automatically adjust for given air temperature:</p> <p>25<Ta<45, 30seconds</p> <p>If 15<Ta<24, 60seconds</p> <p>If 5<Ta<14, 120seconds</p>	
E6	<p>Dehumidification may be disabled. Air heating works normally.</p>	Defrosting error	<p>Speak with your installer/dealer, possible causes: dirty or clogged drain or 4-way valve, too cold, etc.</p> <p>When C25=0 or C25=1 and unit enter defrosting, then if 3 consecutive times AND each time the system exits defrosting based on time = C28 (C8) (and not based on temperature C27 (C7)), then E6 is activated, then compressor off. Heating function is not changed.</p>	no
E7	<p>Serious error, dehumidification is disabled. Air heating function works normally.</p>	Overheat protection, high compressor temperature	E7 – requires correction – described further below.	no
E8	<p>Dehumidification works normally. Air heating is disabled.</p>	<p>High temperature by air heating protection</p> <p>Alternative Phase-sequence protection</p>	IN1=OPEN, (electrical heater protection fuse failure, fan malfunction, filter dirty, system frozen, problem with air flow)	<p>No</p> <p>Fan running for 120 seconds at high speed.</p>

			Alternative phase protection (order of the phases, missing phase, etc.) /3ph 400V units only)	
E9	Dehumidification disabled. Air heating works normally.	Suction temperature sensor error	Check the suction sensor – CN8 black and/or change the sensor.	yes
E10	Dehumidification disabled. Air heating works normally.	Discharge temperature sensor error	Check the suction sensor – CN9 red and/or change the sensor.	yes
E11	Dehumidification disabled. Air heating works normally.	High discharge temperature protection	The device signalizes it is overheating. It will attempt to restart and run the fan at high speed to cool down. If this error is activated 3 consecutive times (within single running period), the system is turned off and E7 (non-recoverable) error is displayed which requires human interaction.	yes
EE	Unit is disabled.	Communication error	Incompatible SW (FW) versions of the PCB and/or display; cable connection.	yes
E12	Unit is disabled.	DC fan failure	Check the cable connection of the display and the PCB and the fan(s). Check PCB for burns.	No
E13	Unit is disabled.	Communication failure between the main board and the DC inverter module	Check the cable connection of the display and the PCB. Check PCB for burns.	No
E14	Unit is disabled.	Too low ambient temperature alarm Snowflake and OFF are flashing 	Increase air temperature. The reason for this error is lower air temperature than settings range within parameter C25 (i.e. less than 9°C or 5°C).	Yes
E15	Electrical heating disabled, dehumidification works normally	Failure of the T6 (CN2) electrical heater sensor	Check the sensor cable and-or replace the sensor. It is 50kΩ copper head.	Yes
E16	Electrical heating disabled, dehumidification	Critical temperature of the electrical coil	Check the air flow, if there aren't objects blocking the air flow	Yes Activation above 120°C, disactivation below

	works normally		Check fan motor if it works normally. Check the unit for dirt and/or any blockage.	90°C
--	----------------	--	---	------

4.3 Humidity control by remote controller - on demand

An external wireless humidistat and thermostat DRY EASY 300 can be ordered for the pool dehumidifier as standard equipped with a built-in digital touch controller (Older units: humidistat and thermostat + mechanical humidistat).



When ordering the DRY EASY 300, there will be no digital humidistat and thermostat 1401F on the cover. The hole in the cover will be covered.

Wireless communication takes place in the 868 MHz band, where the emphasis is on the reliability and range of the controller. The dehumidifier is controlled primarily by a remote humidistat, provided that the built-in humidity controller in the dehumidifier is set to a higher desired humidity value than the remote humidistat.

External wireless humidistat and thermostat DRY EASY 300



1. TRANSMITTER



2. RECEIVER



3. ANTENNA



The manufacturer recommends setting the required humidity value on the DRY EASY 300 in the range of 55 to 65% RH.

If the backup humidistat had been set to a lower value than the DRY EASY 300 remote humidistat, the backup humidistat will take over the room humidity control and in this case the dehumidifier will not respond to signals from the DRY EASY 300 remote humidistat.

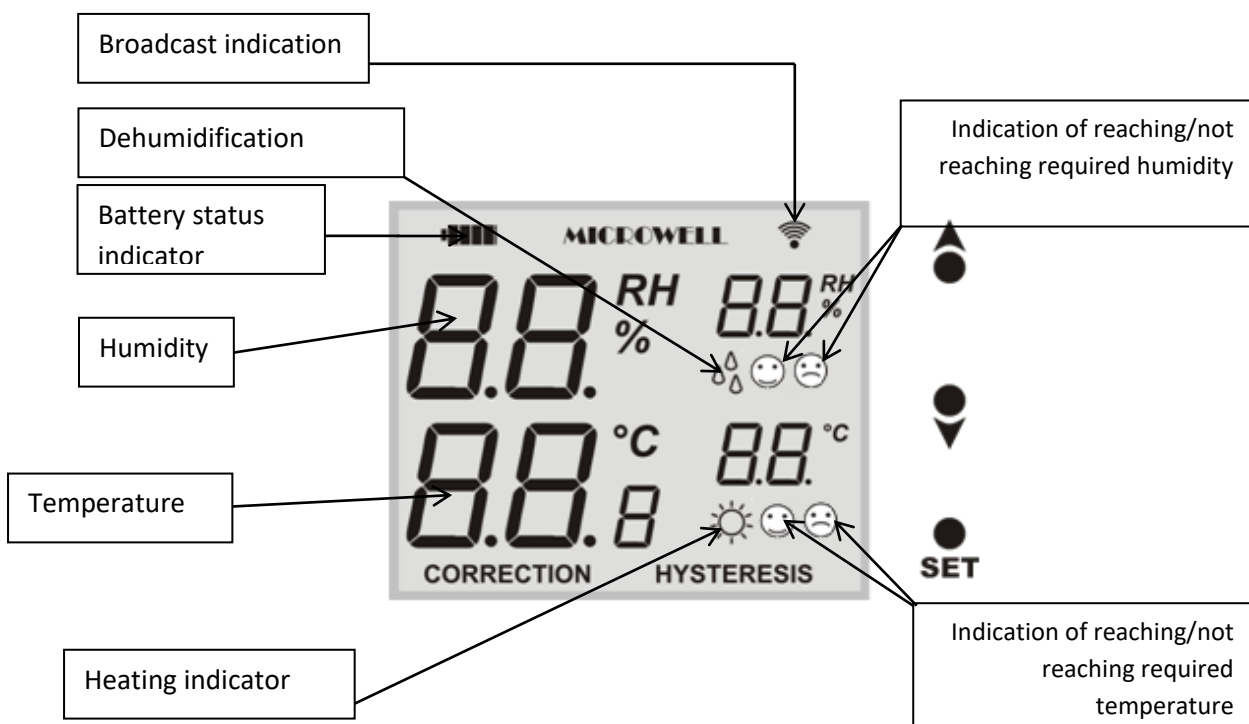



Additional functions and operation of the remote humidistat are described in the separate enclosed instructions.

Location of receiver and antenna

A: The receiver is located inside the electrical box and the antenna is located on the outside of the electrical box.

B: For TTW version /through the wall/, we recommend pulling the antenna into the pipe in the wall. Follow the picture below.

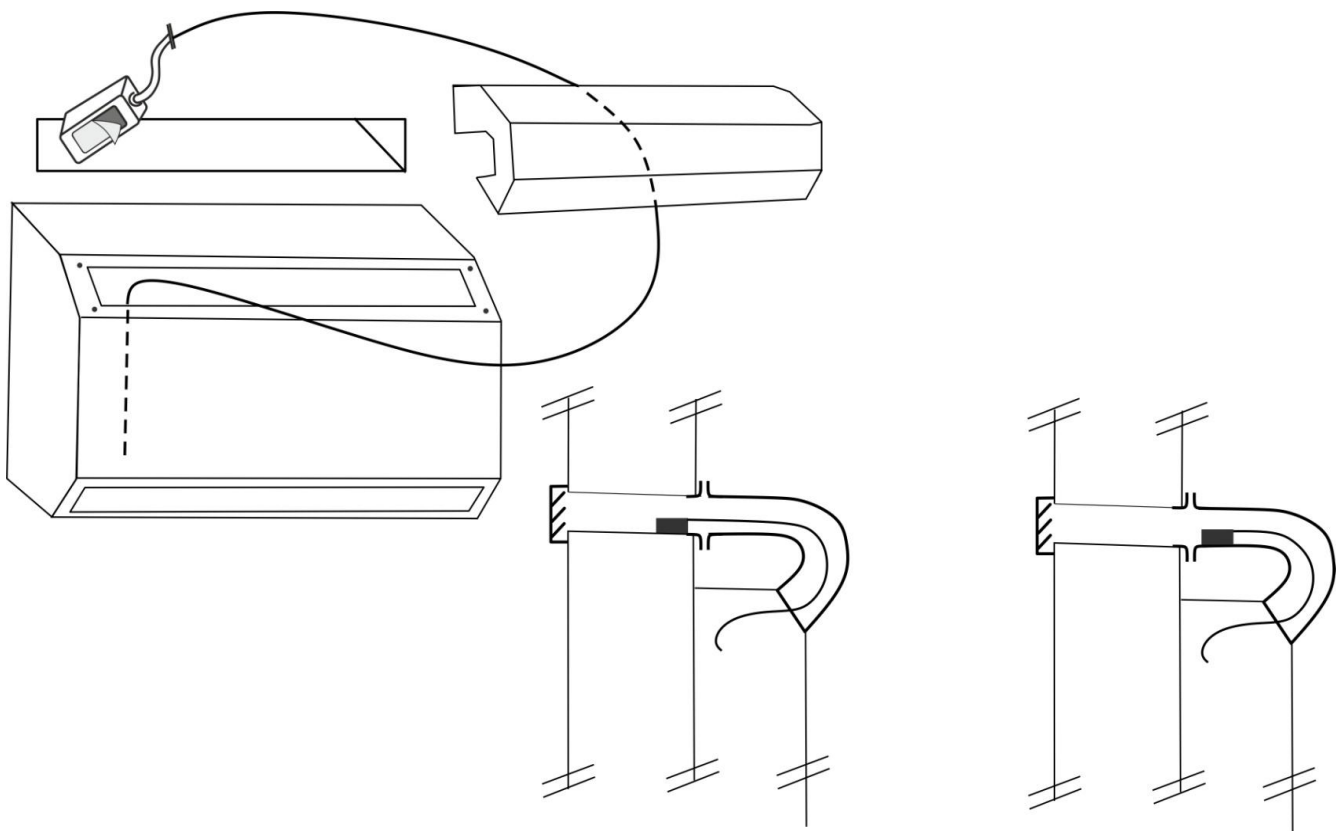

C: If your dehumidifier is also equipped with an electric heater, place the antenna on the outside of the cover. After starting the dehumidifier, test whether the signal is successfully transmitted between the transmitter (display unit) and the antenna. For example, if you set the humidity lower than the current value, then the dehumidifier will start up into its full operation within 3 minutes. The signal is designed to pass successfully over a distance of about 100 meters, through an aluminum fence or steel-reinforced concrete wall. However, the individual conditions of a particular installation may be different. If there is no signal transmission, place the antenna in the lower (suction) air ducting.

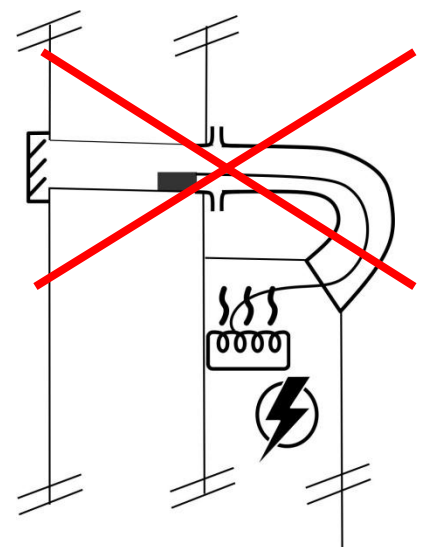

4.4 Humidity control by external wired humidistat EBERLE

If your device is equipped with an EBERLE wired remote humidity controller, pay attention to this section of the installation manual.



Wired humidistat EBERLE HYG6001



Wired humidistat and thermostat EBERLE



When ordering EBERLE HYG6001/7001, there will be no digital humidistat and thermostat 1401F on the covers and the hole in the cover will be covered with a cover.

The dehumidifier can be equipped with a remote humidistat on request. In this case, the dehumidifier has two humidity controllers. One of them is a built-in touch controller (older units: mechanical humidistat) inside the pool dehumidifier, the other is an external wired humidistat. The dehumidifier is controlled primarily by the remote humidistat, provided that the built-in humidity controller inside the dehumidifier is set to a higher desired humidity value than the remote humidistat.

If your dehumidifier is equipped with a hot water insert and/or a solenoid valve also, you must use a humidistat with an EBERLE HYG7001 thermostat to activate the dehumidifier's air heating function, or you must have an external thermostat connected.

4.5 Compressor regulation

The start of the compressor is delayed by 3 minutes due to its protection. Depending on the humidity and ambient temperature, this may take longer. If the compressor stops, it will start automatically after 3 minutes at the earliest. The user must not manipulate the setting element of this time protection. The task of time protection is to equalize the pressures of the refrigerant in the dehumidifier's system.



After a long period of inactivity, it is normal for the compressor to try to start 4-6 times before finally turning on. It also depends on the current air temperature. A lower ambient temperature (approx. 22°C) requires more attempts, a higher temperature (approx. 30°C) usually requires only 1 attempt.

5. INSTALLATION MANUAL



Please note that the screws and dowels supplied with the appliance may only be used on a solid concrete or a brick wall. Please check the base material and select suitable screws and dowels.



The appliance must be installed in accordance with national installation and wiring regulations!



The location of the device must be in accordance with the STN 33 2000-7-702 standard. It is recommended to place the device outside zones 0,1 and 2. When placing the device in zones 2 or 1, the STN must be observed.



It is necessary to place the device outside zones where cleaning with spraying water is expected. Connection to the electric network and protection must comply with relevant standards. The power supply of the device must be realized by a protective isolating transformer or protected by a residual current device with a rated residual breaking current not exceeding 30 mA when installed in rooms where water can be found.

5.1 Locating the device

ZONE 1, IPX4

**Pools that are not cleaned
by water jet**

at a distance of 1250 to 2000 mm from the edge of the pool
they must comply with STN and at least 300 mm from the floor.

ZONE 2, IPX2

**Pools that are not cleaned
by water jet**

at a distance of 2000 to 3500 mm from the edge of the pool must be in accordance with STN and is required min. 150 mm elevation above the floor due to sufficient airflow, installation of the device on the floor is prohibited.

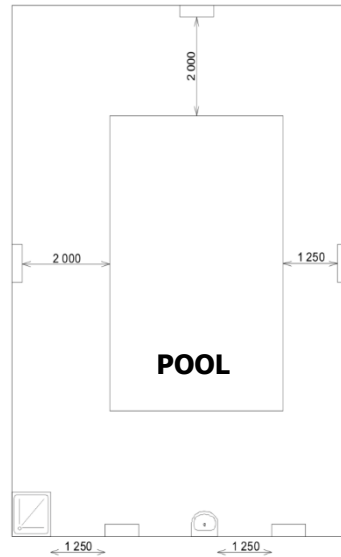

OUTSIDE ZONE

at a distance of less than or equal to 1250 mm from the edge of the pool, the lower edge of the device must be at a height of 2500 mm from the surface of the pool, if it is recessed under the floor or from the floor.

min. 1250 mm (i.e. out of reach) from the side edge of the shower enclosure, cannot be above the shower enclosure.

min. 1250 mm (i.e. out of reach) from the side edge of the sink at a height of min. 1200 mm from the floor, cannot be above the sink.

OUTSIDE ZONE

at a distance of min. 1500 mm from the vertical plane around the jumping platforms, jumping boards and starting blocks and 2500 mm above the highest surface on which people are expected to be present.

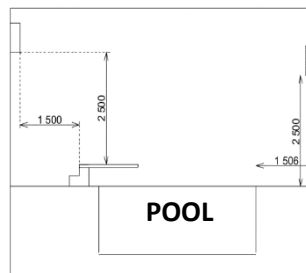

OUTSIDE ZONE

if the unit is at a distance less than or equal to 1250 mm horizontally from the edge of the pool, then it must be lifted 2500 mm from the surface of the pool, if it is recessed under the floor and from the floor.

MICROWELL DRY 800/1200 METAL are designed to be installed directly in the pool hall. All models are protected by electrical protection class IP44.

1. In order to be as efficient as possible, the appliance must be installed as high as possible but not completely below the ceiling. Leave min. 200mm free space above the device. Due to maintenance, it is also necessary to leave free space of min. 200 mm on the sides of the device.

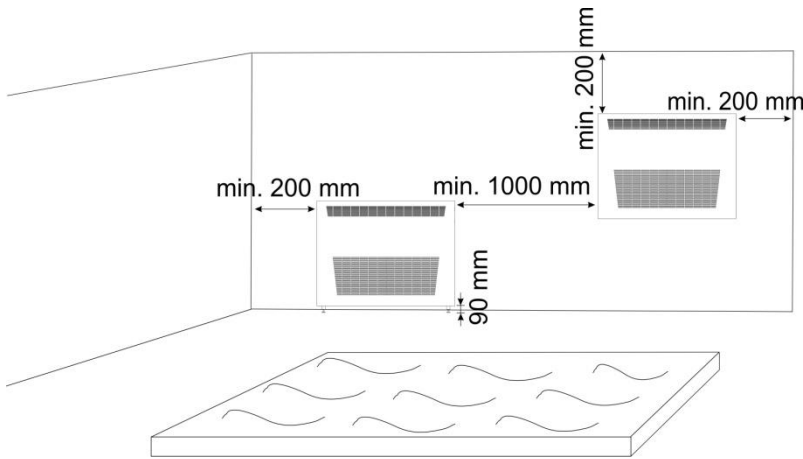

2. It is not advisable to mount the dehumidifier close to heating elements, as the dehumidifier could suck in heated air and this could delay its regulation. Also, placement above, for example, a radiator can cause the device to overheat, malfunction, or be damaged. It is also not advisable to place the dehumidifier near open windows, as it could suck in outside air and it could also delay its regulation. The suction of outside air causes the moisture from the pool hall not to be resolved and thus to accumulate in the pool hall.

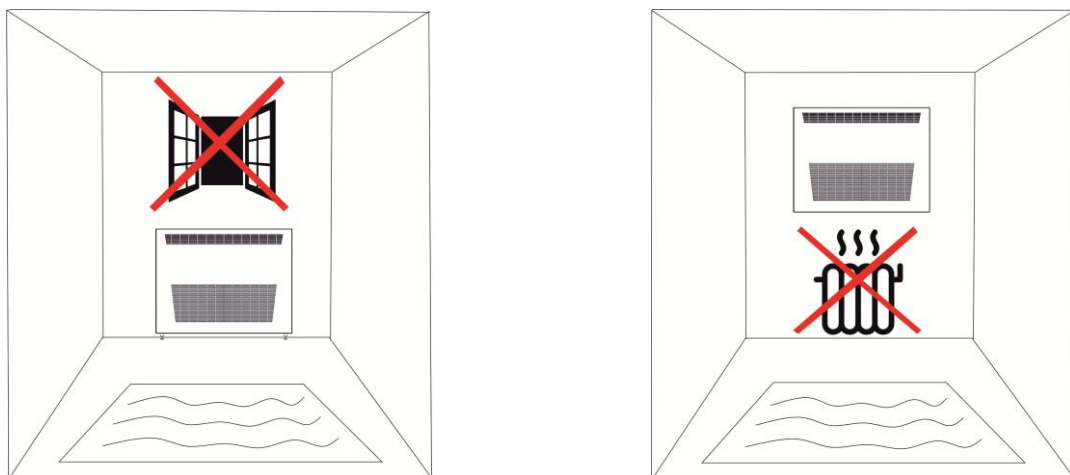

3. If two dehumidifiers are used in one room, it is recommended to install the devices further apart to ensure correct air flow in the pool hall and to achieve the desired humidity control effect. Installation too close to each other can cause dry air to circulate between the devices. This can result in excessive humidity in part of the pool hall. We also recommend maintaining a distance of at least 1 meter between the devices for future installation and service.

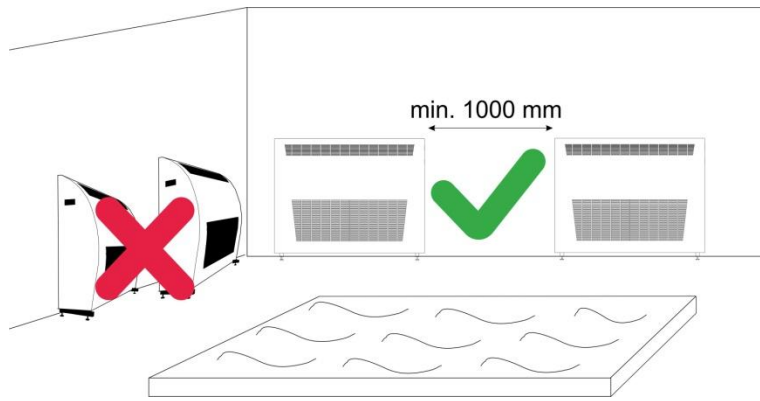

4. Always install the dehumidifier so that it can dehumidify pool air. In case of a structured pool hall, or a separate part – the placement of a dehumidifier is not suitable as the air flow will not be sufficient, thus the desired dehumidification effect may not be achieved.

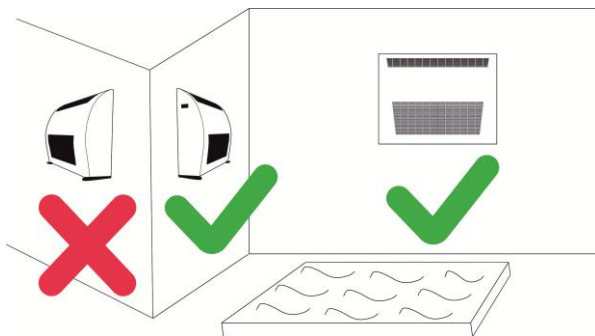

5.2 Installation of device

1. Cut the fixing tapes

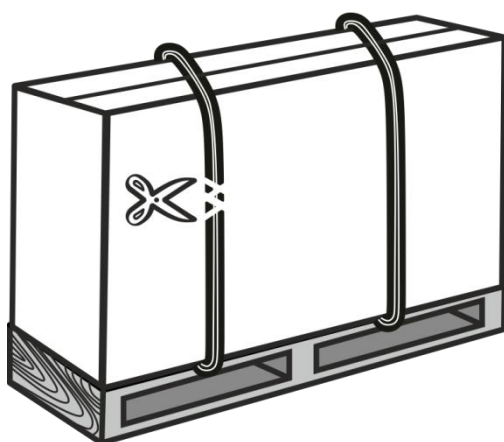

2. Slide out the cardboard box

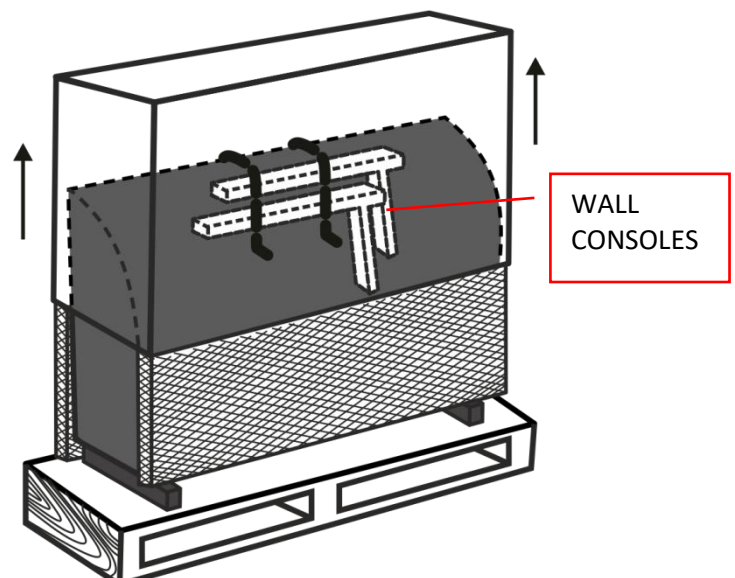

3. Remove the 4 M8 screws that secure the dehumidifier to the pallet.

WARNING! Do not unscrew the M6 screws. After removing these screws, there is risk of the device falling.

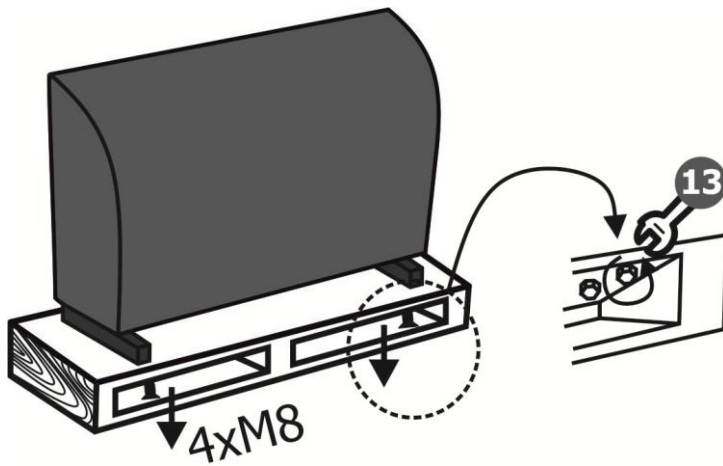

9.2.1 Floor installation

1. After removing 4 M8 screws, insert 4 rubber feet instead.

2. Floor installation is complete. Finally, attach the dehumidifier to the wall as shown below.

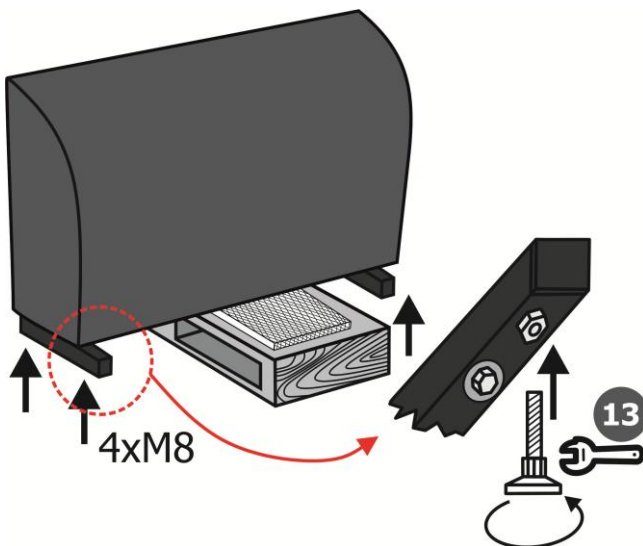

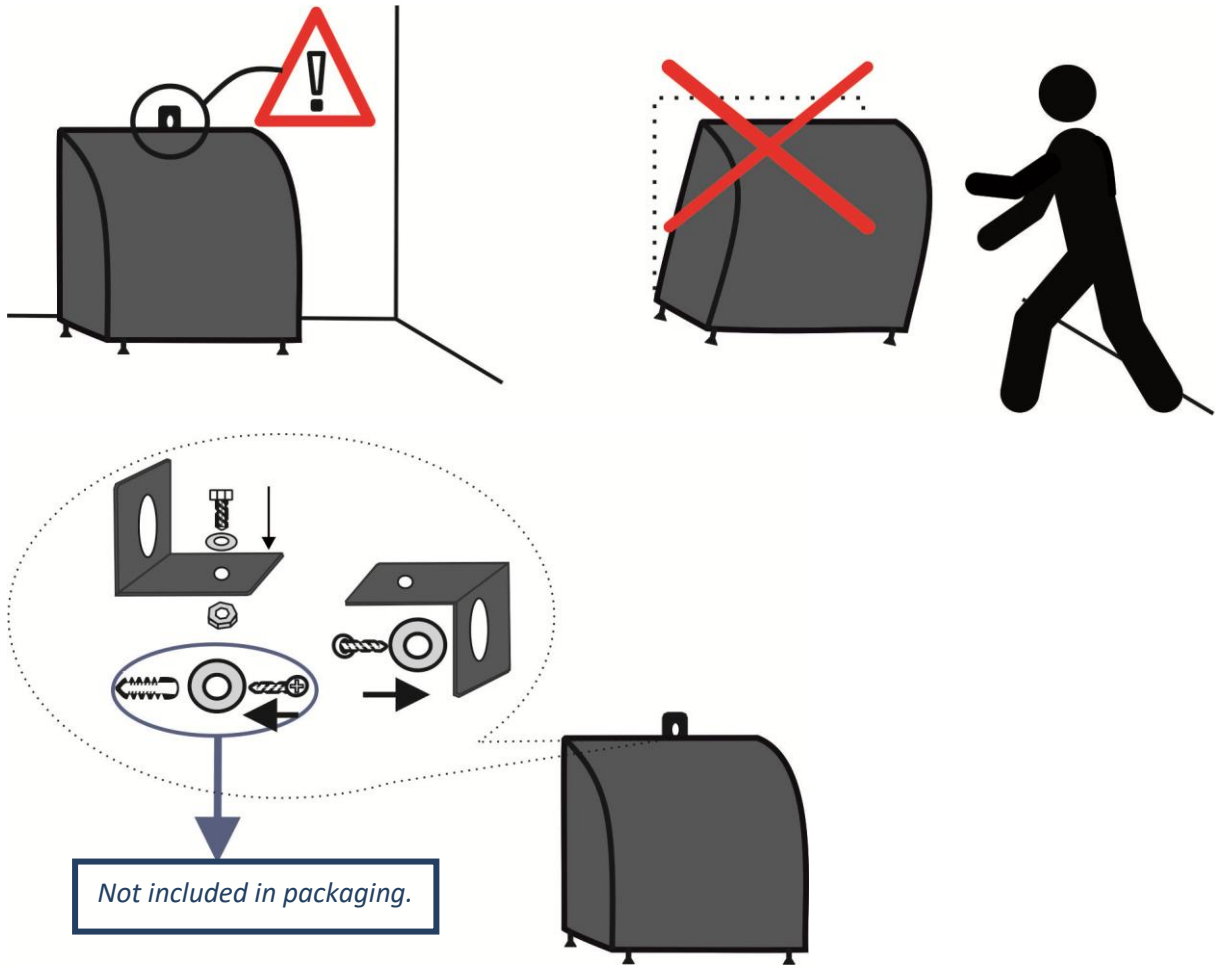

9.2.2 Wall installation - on demand

If the dehumidifier is being installed on a wall, it is necessary to order a set of brackets for wall mounting. This is used instead of the legs that come standard with the device. The set of brackets for wall mounting consists of:

- pcs d 10 mm nylon dowels length 160 mm for anchoring in solid brick and concrete
- pcs M8 dowel screws
- 4 pcs M6 screws for attaching the dehumidifier bottom through the brackets

Each bracket is attached to the wall with three screws through the holes in the bracket into the dowels on the wall. The brackets must be mounted at a distance from each other as shown in the figure below. After mounting the device on the brackets, the device at the bottom must be screwed to each bracket with two M6 screws.

Installation procedure:

Remove the supplied feet (which fixed the device to the pallet). You can remove them on the floor, lift the whole unit and place it on the wall. Or you can install the wall brackets first and then lift the unit and then remove the feet.

Be careful not to place the cover/unit on the floor without feet. There is a risk of scratching and damaging the cover.

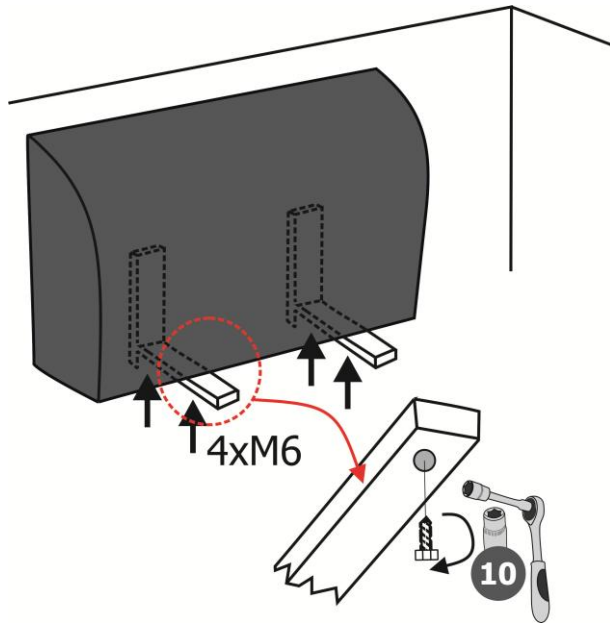

9.2.3 THROUGH-THE-WALL installation - on demand

Dehumidifiers are also easily adapted for installation behind a wall in a side room. Only two grilles are then visible in the pool hall area. In the version behind the wall, there are holes on the back plate of the dehumidifier for connecting pipe extensions. The extensions are supplied in a length for penetration through a wall 400 mm wide. On site, they are then shortened to measure by the pool hall.

SIDE VIEW

VIEW FROM THE POOL HALL

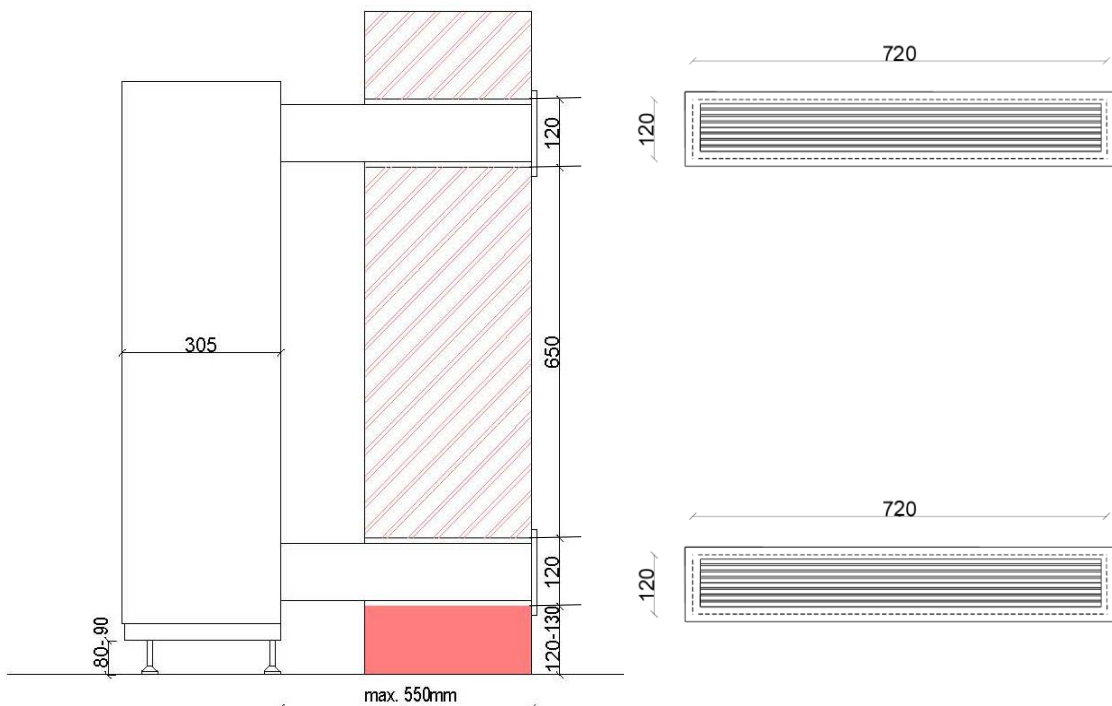

The dimensions of construction openings are annotated.

REAR VIEW - Intake and exhaust positions on the back of the dehumidifier and fresh air supply

Heating water supply to hot water
inserts on the right side/when viewed from the front

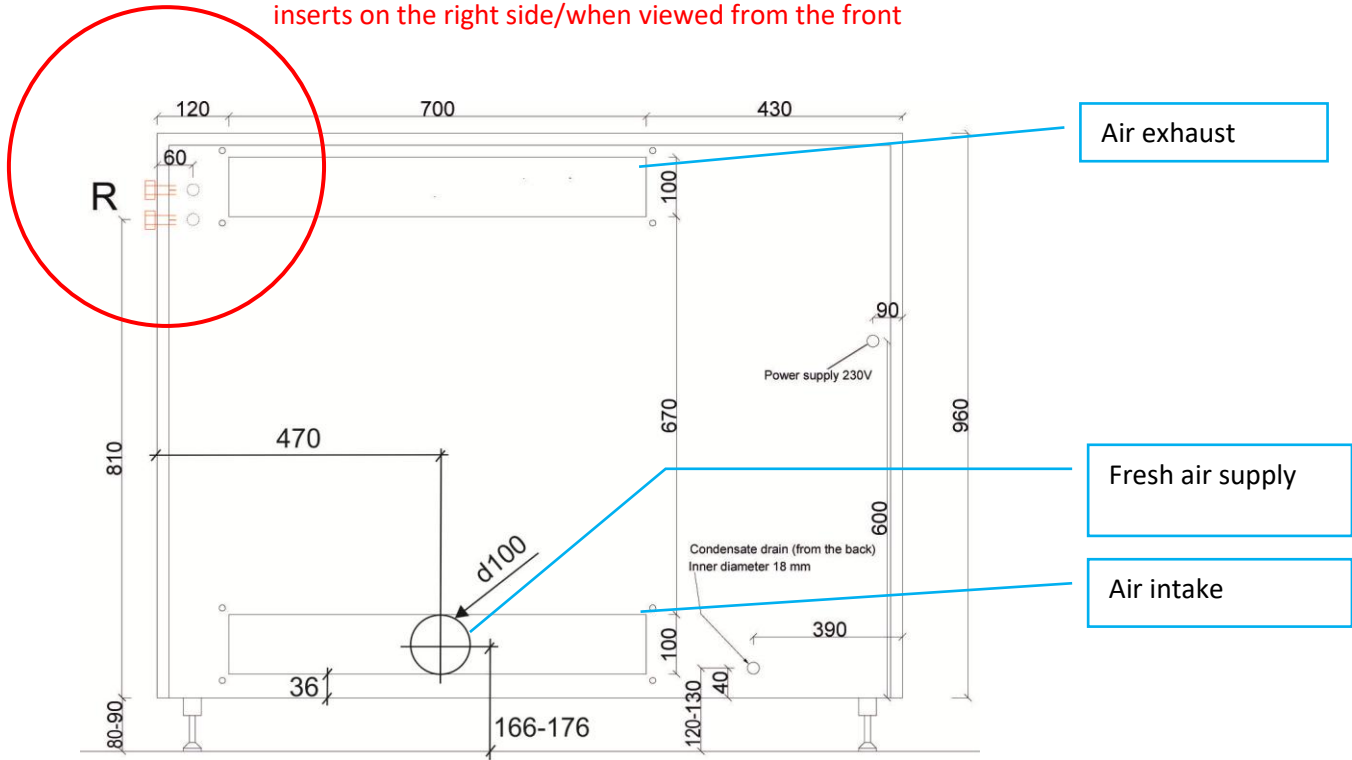

Heating water supply to hot water
inserts at the back of unit

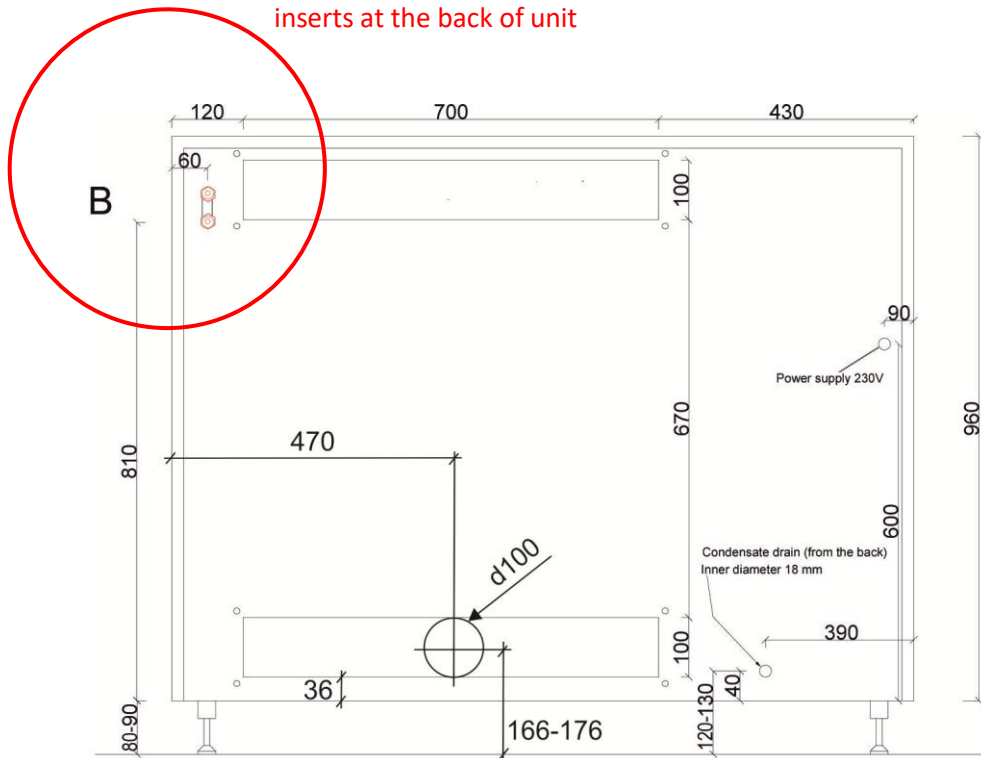

FRONT VIEW

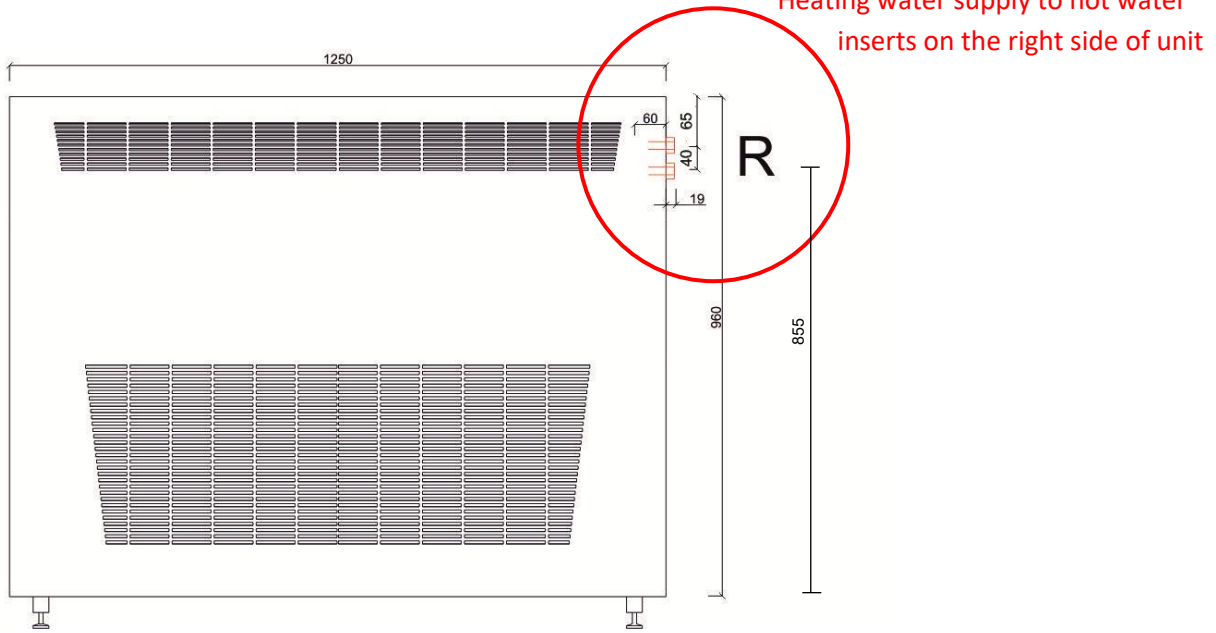

SIDE VIEW

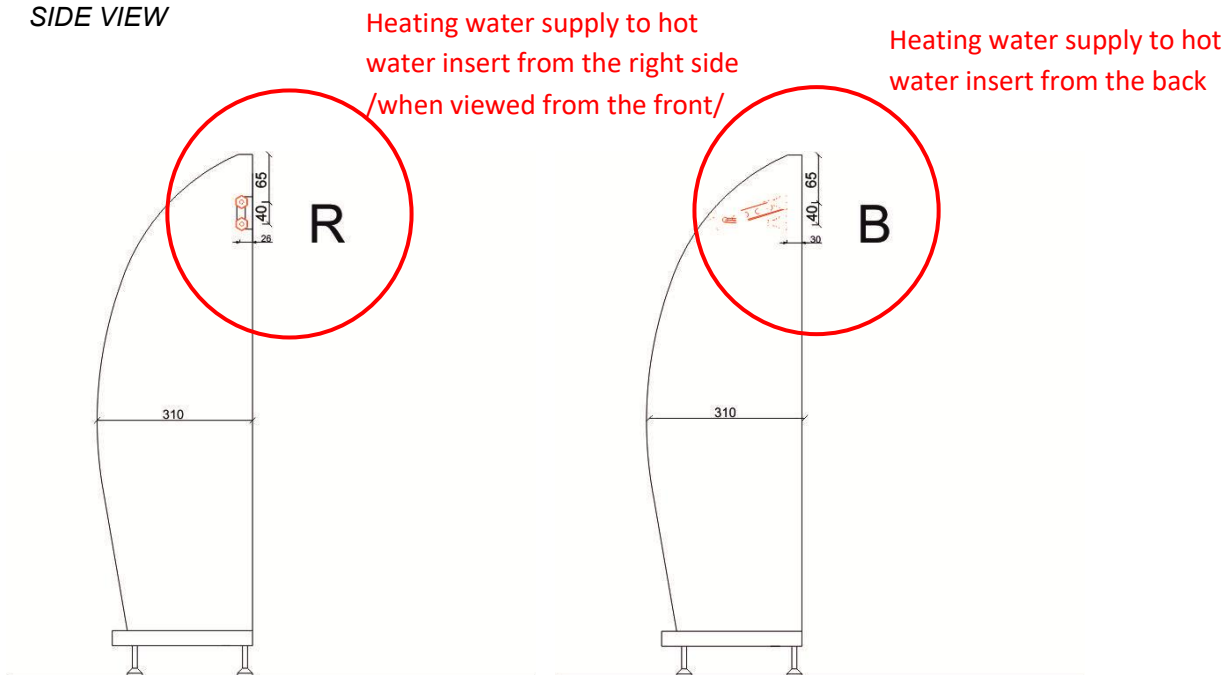

COVER REMOVAL

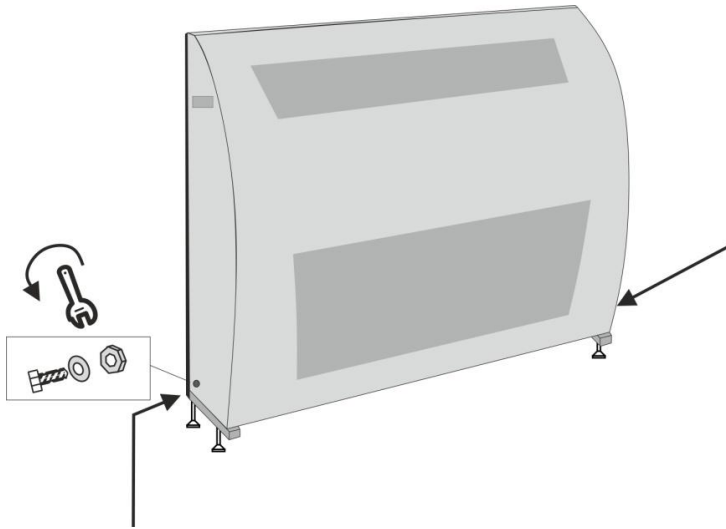

Lower the side cover caps, unscrew and remove the side cover screws.

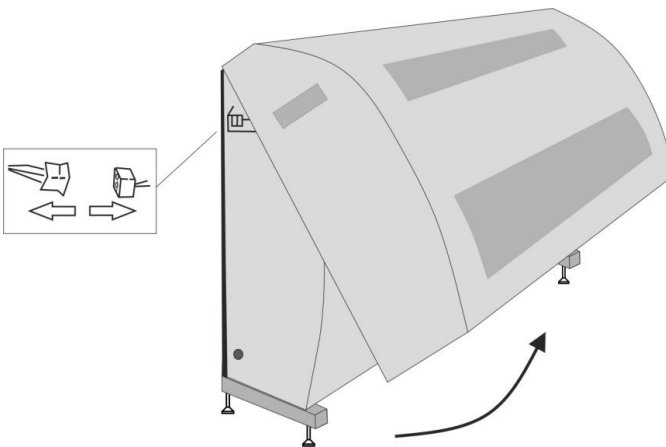

Lift the cover as shown in the illustration.
Disconnect the connectors on the display on the left side under the cover.

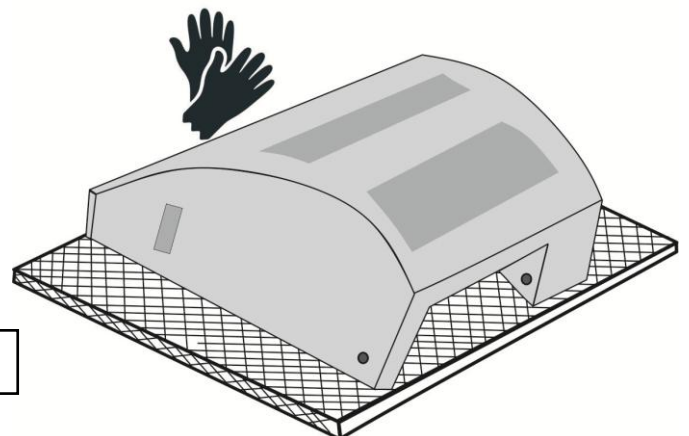
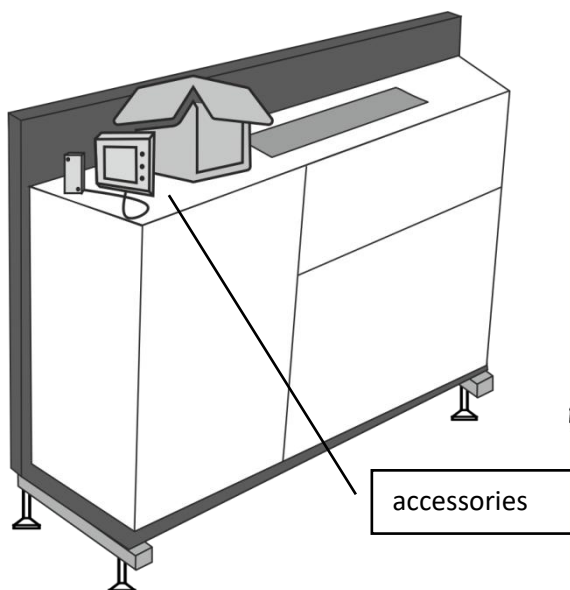

Place the cover sideways on a foam pad or cardboard so that you do not scratch the cover on the floor. Use soft gloves when handling the kit.

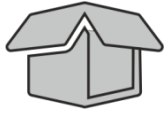

Take out the additional accessories packed in the cardboard box under the cover (wireless humidistat and thermostat DRY EASY 300, solenoid valve, heating insert).

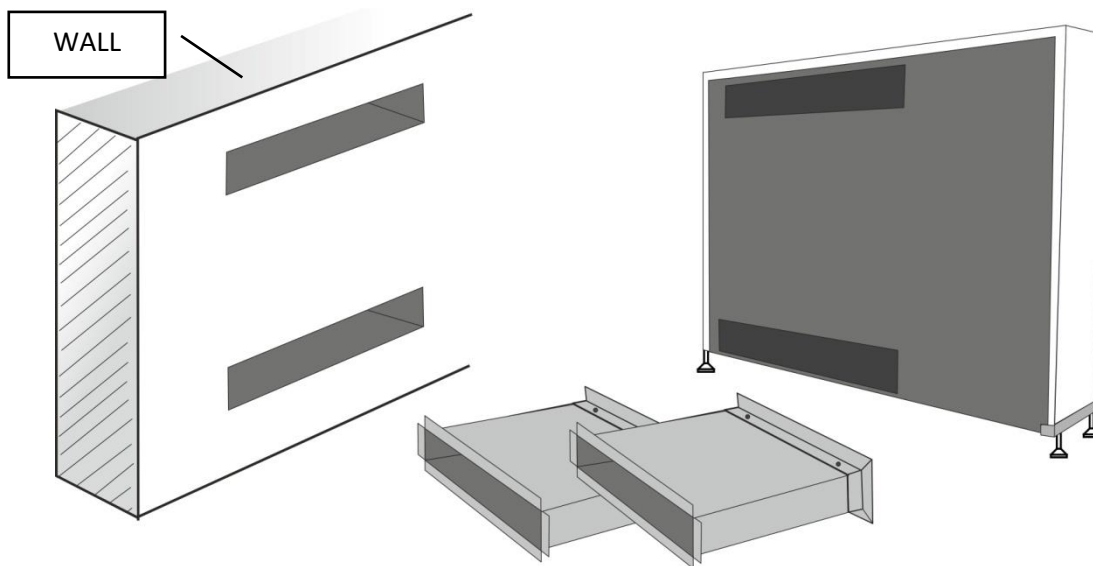

Prepare the holes in the wall, pipe fittings and dehumidifier for the installation site.

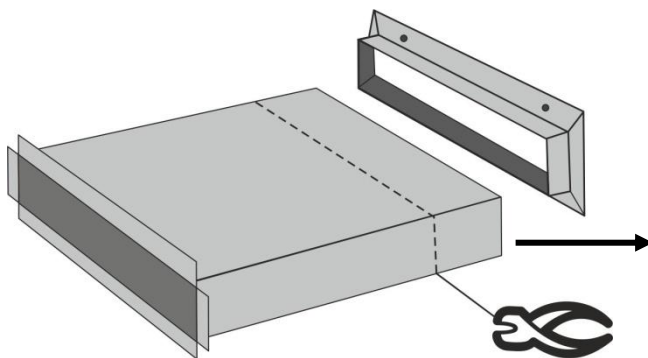

Remove the flange, cut the pipe as required.

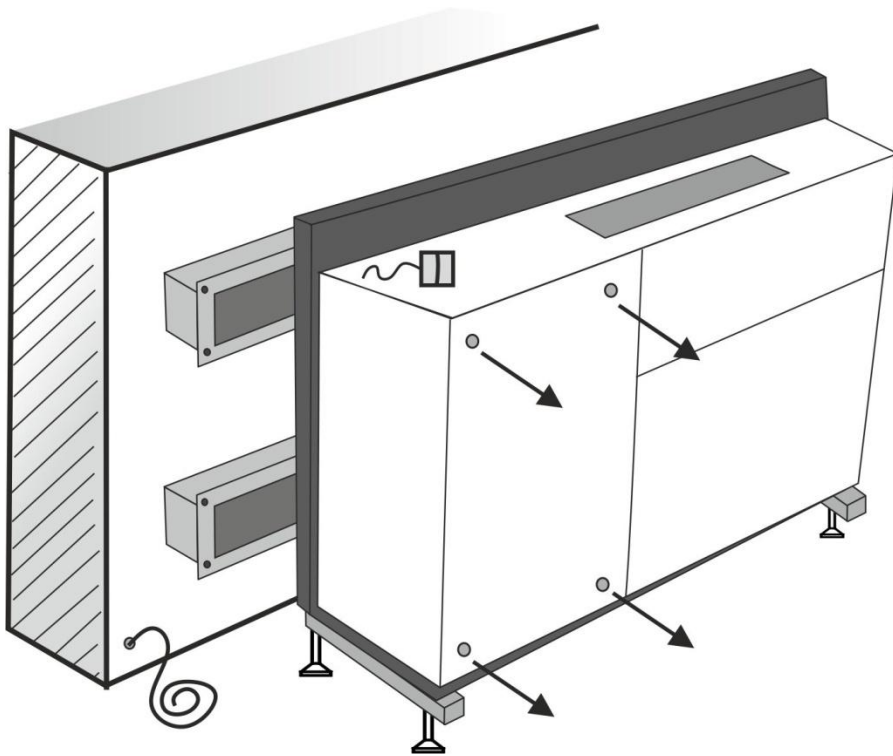

Lower the inner cover on the left.

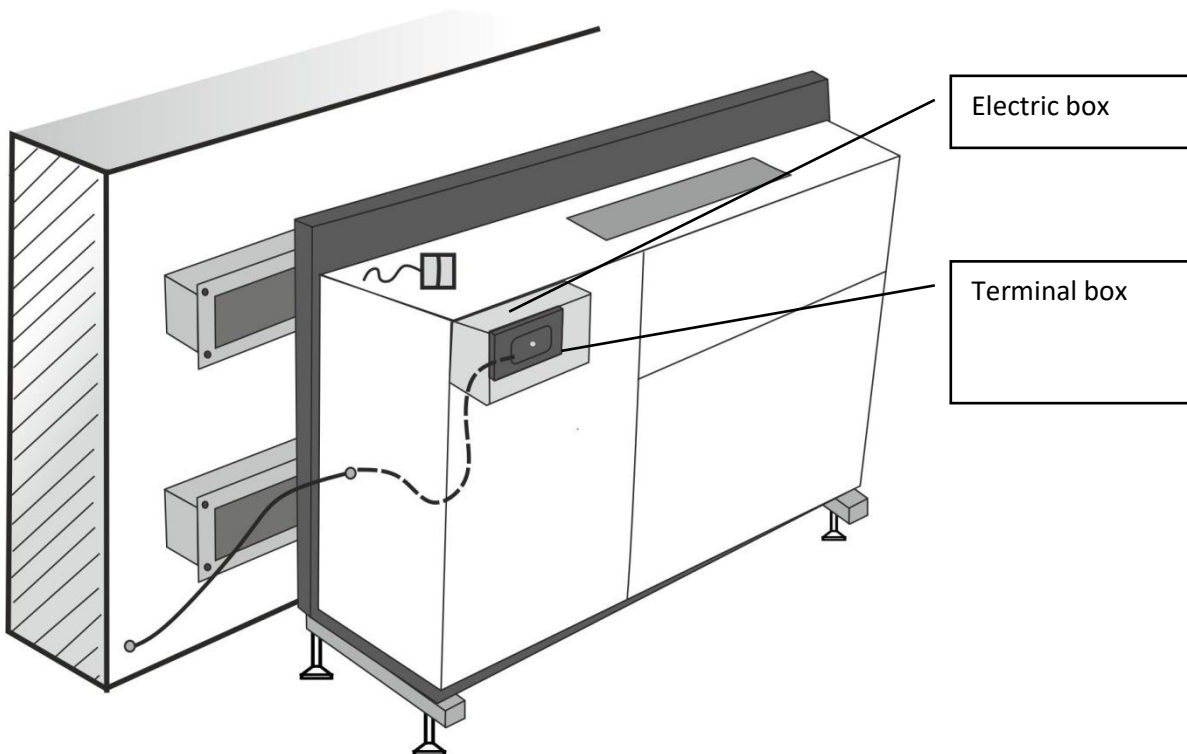

Slide the dehumidifier against the wall to the pipe fittings, connect the electrical cable and the condensation hose.

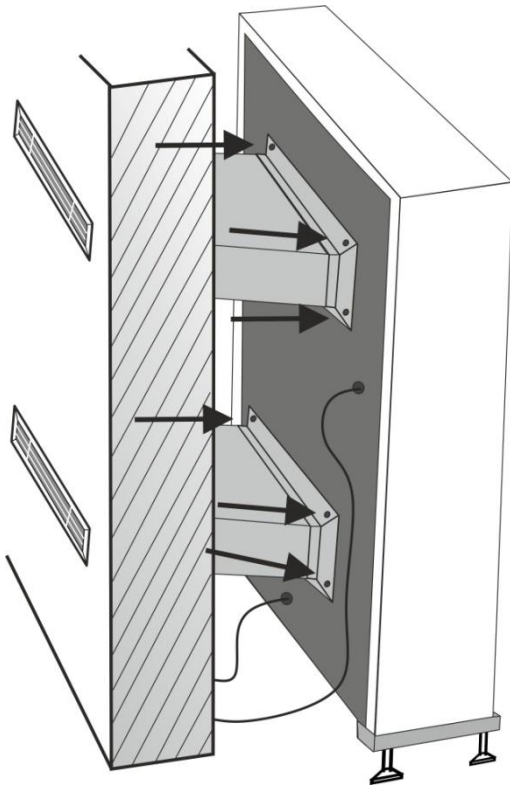

Slide the dehumidifier onto the pipe fittings and screw the pipe fittings onto the rear wall of the dehumidifier.

Fill the gap between the pipe fittings and the holes in the wall with PUR FOAM.

Replace the dehumidifier cover the same way you removed it.

Proper grille installation

When fitting the grilles, pay attention to the inclination of the slats and fit the grilles as shown below.

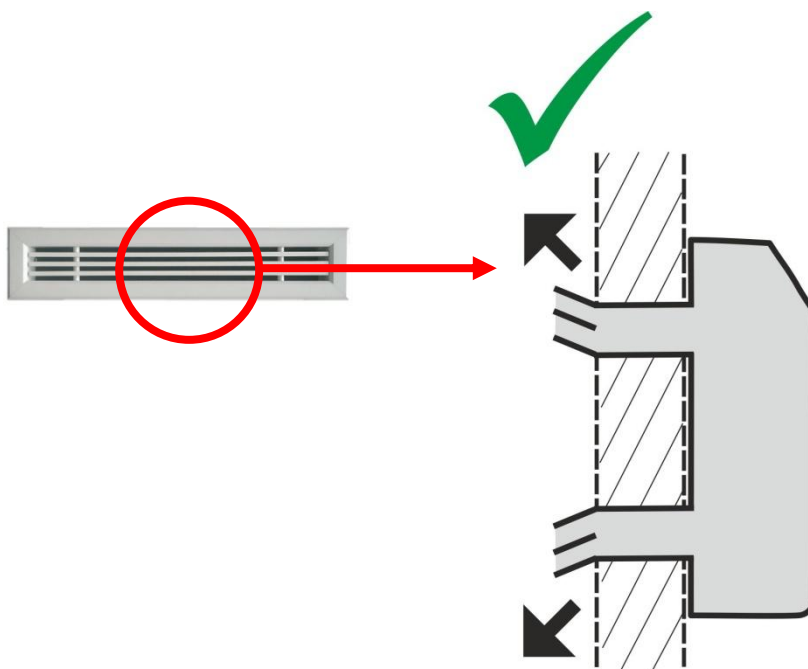

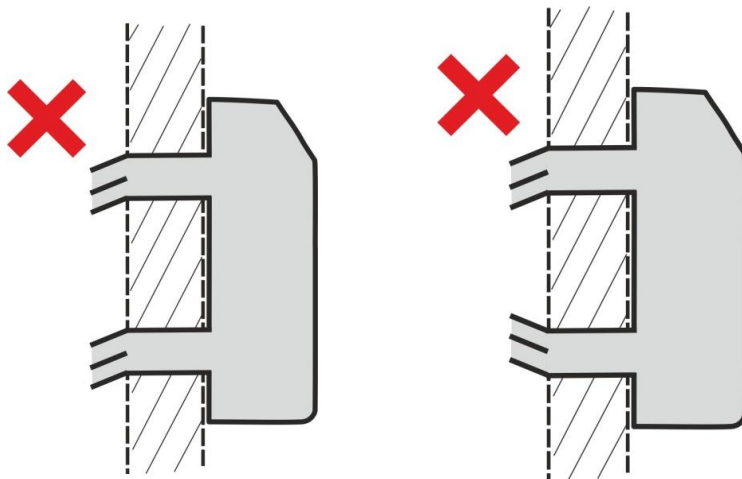

THROUGH THE WALL INSTALLATION WITH THE UNIT ON THE WALL

Your unit may have been ordered and manufactured as wall installation and through the wall. In this case it is advised to affix the straight air ducting on the unit from the back before placing the unit on the wall consoles. For the wall installation please refer to section 5.2.2. Wall installation – on demand.

Procedure how to affix the through the wall ducting described below.

1.

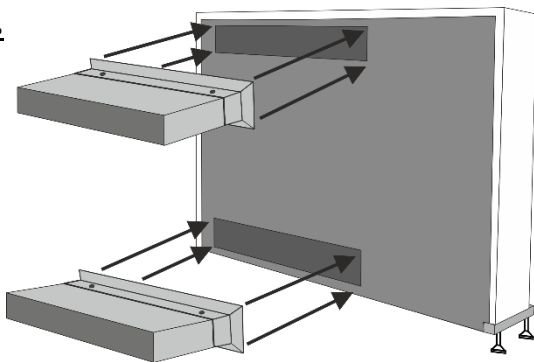

2.

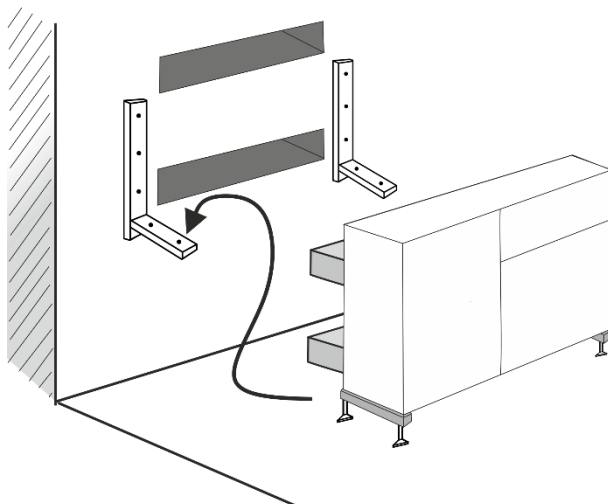

3.

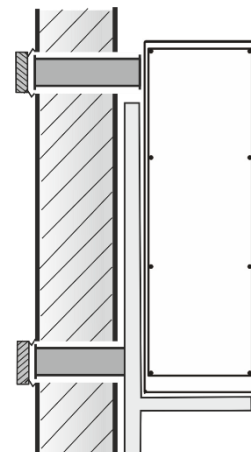

9.2.4 Compressor protection during transport

The compressor is protected during transport by plastic straps. This requires the size and weight of the compressor so that the equipment delivered to you is safe and fully functional. This protection must be removed before starting the dehumidifier (see pictures below). The process usually takes a few seconds. Please note that warranty conditions cannot be applied without removing the plastic tapes.



Img. 1: Illustration of the factory-fitted plastic strap.



Img. 2: Cut the tape with a suitable tool.

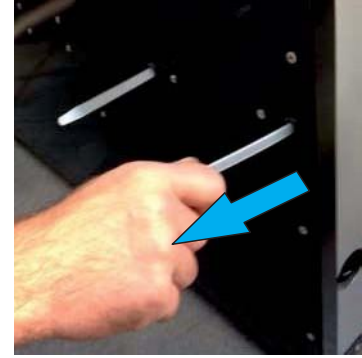

Img. 3: Finally, pull the tape out of the device and remove it.

5.3 Condensate drain

When drying your pool hall, your dehumidifier will condense the water that is fed into its internal collection tray. Without active (free) condensate drainage, the dehumidification process will not work. Condensation water is drained from the dehumidifier by gravity (downwards). The condensing tray has the correct slope when the dehumidifier is mounted horizontally (using a spirit level). Condensed water must be drained through a siphon to the sewer or to the outside environment. Please do not place the drain hose upwards (against gravity), as this may cause the appliance to be unable to drain water condensate. This in turn will cause water to leak from under the unit cover and may lead to unit failure, damage, or failure. It can also cause the floor to get wet, creating the risk of injury and damage to health from unwanted slipperiness. The manufacturer, distributor or dealer is not liable for such damages. We recommend using the **HL 138** concealed siphon designed for air conditioning units in the condensate drain. This must be located min. 20 cm below the condensate outlet from the dehumidifier. The pictures below show more.



Warning:

Condensed water from the dehumidifier must not be collected in the collecting container drunk! Condensed water from the dehumidifier must not be returned to the pool!

HL138

0,15 l/s
DN 32

1. Ø20-32mm
DN32

2.

3.

4.

5a.

5b. min. 20 cm

6.

DE KLIMAGERÄTE - EINBAUSIFON
IT SIFONE AD INCASSO PER CONDENSATI
GB IN-WALL CONDENSATE SIPHON

H KLÍMAZFON FALBA SÜLLYESZTVE
PL SYFON PODTYNKOWY DO SKROPLIN
SI VGRADNI SIFON ZA KLIMA NAPRAVE

CZ/SK PODOMÍTKOVÝ SIFON PRO KLIMATIZ JEDNOTKY
HR UGRADBENI SIFON ZA KLIMA -UREĐAJE
RO SIFON DE CONDENSATJE

TR SPLIT KLIMALAR İÇİN GÖMME SIFON
PYC СИФОН ДЛІЯ КОНДИЦІОНЕРОВ
BUL КОНДЕНЗАТЕН СИФОН ЗА ВГРАЖДАНЕ

03.08.2011

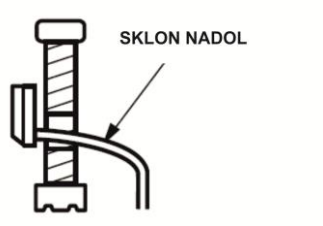

Proper installation of condense hose

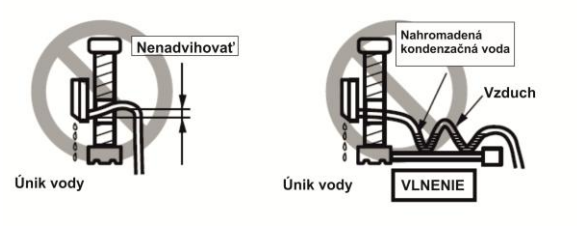

Improper installation of condense hose

CONDENSATE DRAIN

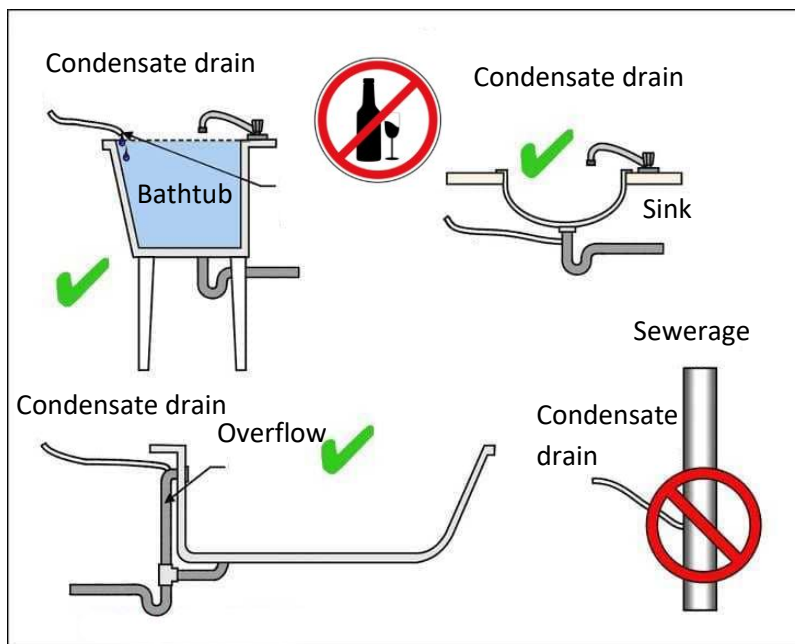

5.4 Main power supply connection

5.4.1 Main electrical connection for fixed cable in wall

As standard, the dehumidifiers are connected to a fixed cable in the wall. Connecting the device to an el. network must comply with the relevant security standards. Connection requirements are: Power supply: 220-240 V / 50 Hz / 1f. Fuse: 16A (DRY 800/1200) with residual current device (RCD) with a rated residual current not exceeding 30 mA. The main switch of the device must be located outside the pool hall. The main switch of the appliance must be bipolar with the switch of the L and N wires. The appliance must be placed on a solid surface to disconnect the appliance from the mains. The distance between the contacts, when switched off, must be at least 3 mm for all poles.

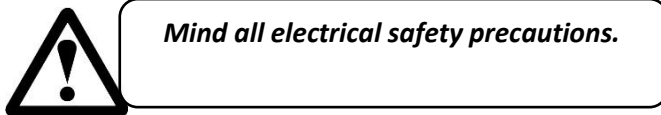
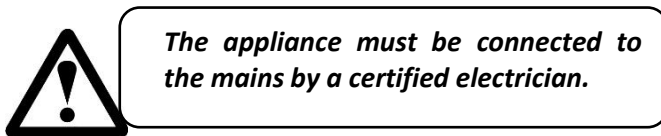

The mains terminal block is located in this black box

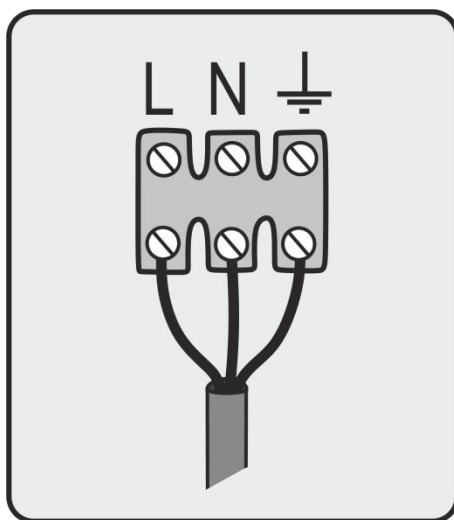

Standard terminal block -
L, N, ground

Main power supply		
Dehumidifier type	El. cable	El. insulation
DRY 800	CYSY 3x 2,5 mm ²	16 A type C
DRY 1200	CYSY 3x 2,5 mm ²	20 A type C

El. connection of a potential-free contact for a cooperating hot water heating system		
Dehumidifier type	El. cable	Power supply
DRY 800/1200	CYSY 2x 1,5 mm ²	via contactor

Electric heating element connection		
Dehumidifier type	El. cable	El. insulation
DRY 800/1200	CYSY 3x 2,5 mm ²	16A

El. connection of wire humidistat and thermostat	
Model	El. cable
HYG6001	CYSY 4x 1,0 mm ²
HYG7001	CYSY 5x 1,0 mm ²

5.4.2 El. connection of external humidistat and thermostat

The connection of the EBERLE HYG6001 (HYG7001) cable remote humidistat is made at the installation site. The manufacturer does not supply the connecting cable.

EBERLE HYG6001 connection for DRY 800/1200

HYG-E 6001

MAIN EL. CONNECTION OF DEHUMIDIFIER
230V/50Hz/1f
3x 2.5mm² CYSY
breaker 16A (DRY800) / 20A (DRY1200) type C
circuit breaker 30mA

Black box from the SIDE of the electrobox

R 410A 1,4kg

EBERLE HYG7001 connection for DRY 800/1200

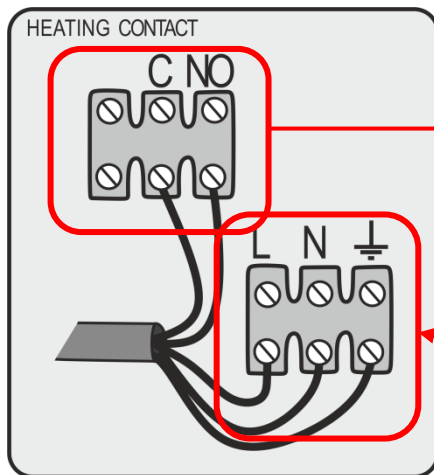

Black box from the *SIDE* of the electrobox

POTENTIAL-FREE CONTACT

- NO /normally open/
- If the air is heated, then C /closed/

MAIN ELECTRICAL CONNECTION OF THE DEHUMIDIFIER

230V/50Hz/1f
3x 2.5mm² CYSY
Breaker 16A (DRY800) / 20A (DRY1200)
type C
Circuit breaker 30mA

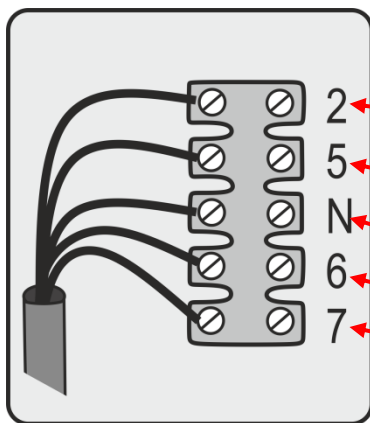

Black box from the *FRONT* of the electrobox

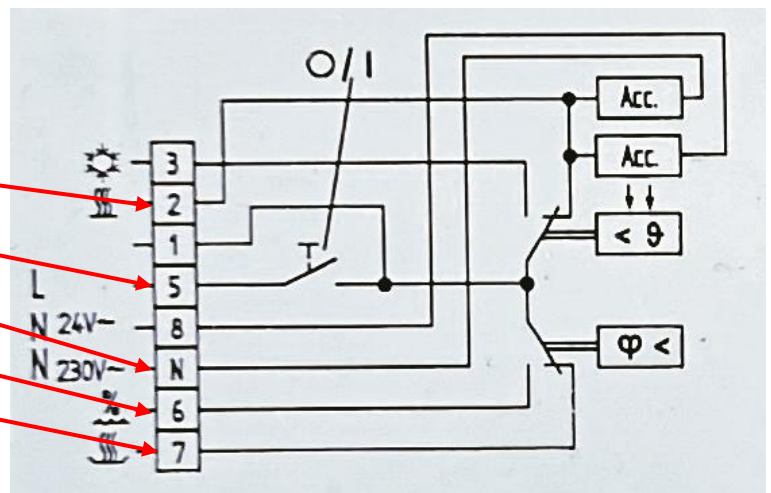

Electric heating element connection for DRY 800/1200

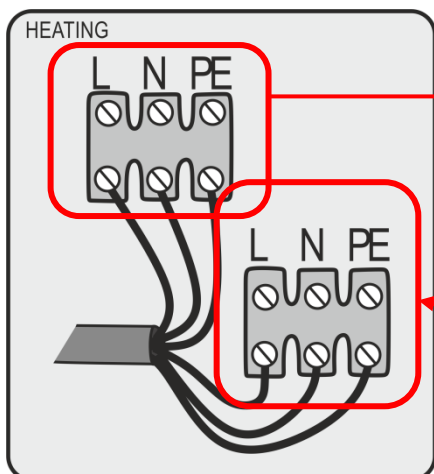

Black box from the *SIDE* of the electrobox

EL. HEATING POWER SUPPLY

230V/50Hz/1f
Kábel: 3x2.5mm² CYSY
Príkón: 2.5kW
Istič: 16A

MAIN ELECTRICAL CONNECTION OF THE DEHUMIDIFIER

230V/50Hz/1f
Cable: 3x 2.5mm² CYSY
Breaker: 16A (DRY800) / 20A (DRY1200)
type C
Circuit breaker: 30mA



The functions and operation of the remote humidistat are described in a separate enclosed manual.

5.5 LPHW hot water insert for additional heating – on demand

The LPHW heating element is only available on request. The connection of the LPHW hot water insert is made similarly to the connection of the radiator. A control valve is connected at the inlet and a shut-off valve with a screw connection at the return. These are supplied by the heating supplier.

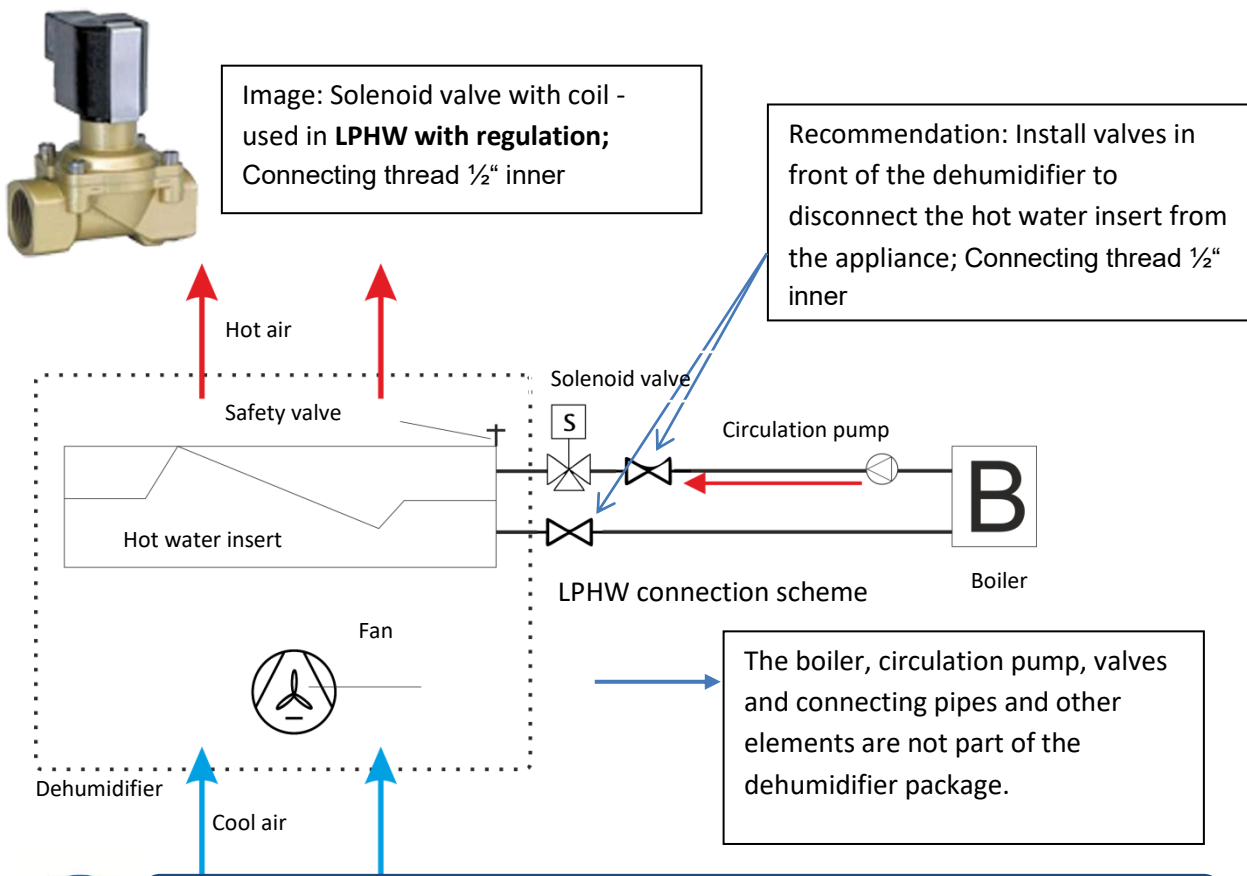

Please note that DRY 800/1200 are not equipped with a thermostat and a potential-free heating contact by standard.

Parameters of the solenoid valve:

- dimension DN 12,
- operating pressure PN 10,
- threaded connection,
- control: coil
- 230V (D-233),
- material: brass,
- controlled directly,
- type: 8253 12D 1 12 2 1 230V AC

No.	Item	Material
1	Safety nut	Galvanized steel
2	Washer	Galvanized steel
3	Coil	PBT + 30% G.F
4	Piping	Stainless steel AISI 430
5	Seal	FPM
6	Screw	Stainless steel
7	Cover	Brass CW 617 N
8	Spring	Steel
9	Ring	Stainless steel
10	Piston	Stainless steel
11	Spring	Steel
12	Support	Stainless steel
13	Insulation	NBR
14	Spring	Steel
15	Cover	Stainless steel
16	Membrane	NBR
17	Cover	Stainless steel
18	Body	Brass CW 617 N

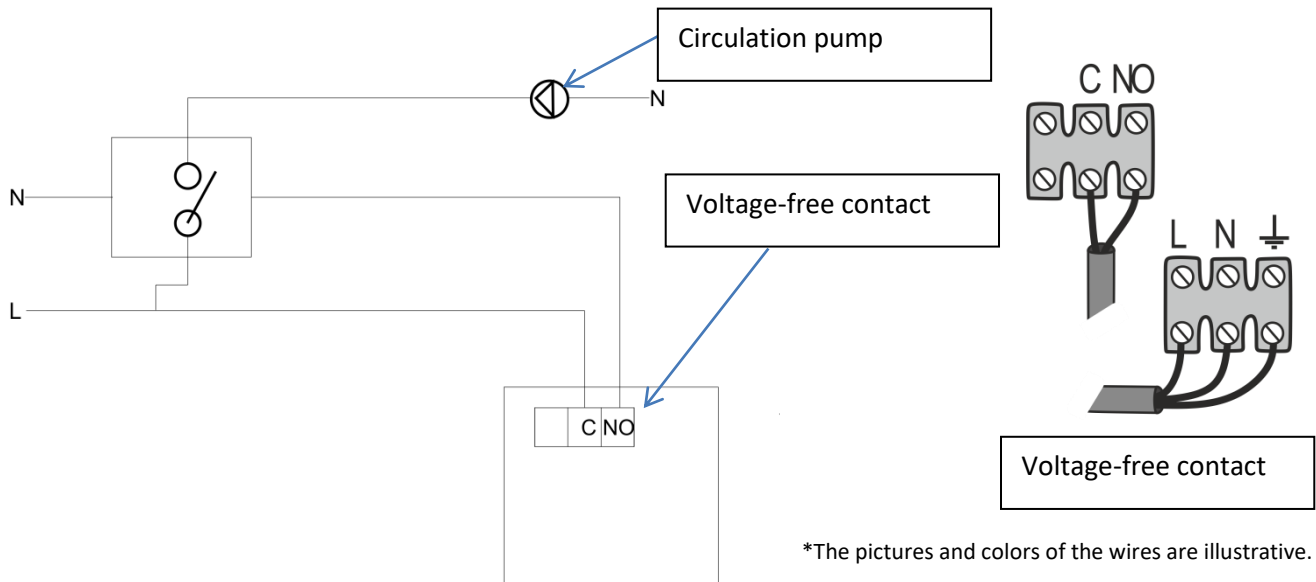
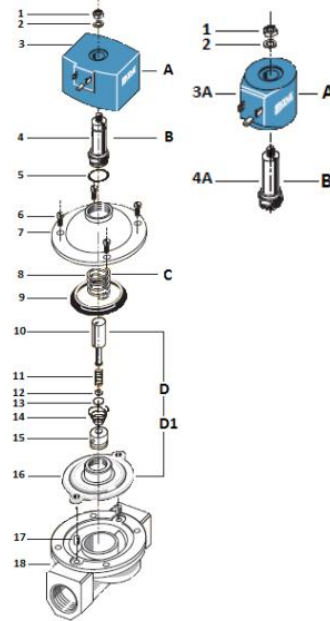

The dehumidifier can be equipped with a solenoid valve on request. When used in combination with a hot water insert, it has a similar function to the fan coil, i. the fan works independently with the compressor (humidistat) and independently with the LPHW hot water insert (thermostat).

Heat output of heating element LPHW (W)	
DRY800/1200	
90/70/30°C	7000
80/60/30°C	5880
70/50/30°C	4690
55/45/30°C	3010
45/35/30°C	1407
Water flow (l/min)	6
Pressure drop (kPa)	24.1
Connecting thread	½"inner



It is recommended to insert a shut-off valve between the LPHW hot water insert and the heating source. This will allow it to be quickly disconnected from the heating system in the event of a fault in the heating system and maintenance of the system or dehumidifier.

5.6 Electric heating

On demand, your pool dehumidifier can be equipped with an electric heater. It consists of a durable stainless-steel tube in aluminium heat exchanger. Capacity 2,5 kW for DRY800/1200. The electric heater has a separate power connection, which is located in the black box the dehumidifier connection to the power supply located in the dehumidifier electrical box.



The electric heater is equipped with two safety switches.

The electric heating is switched on and off according to the set required air temperature on the dehumidifier controller / digital built-in or wireless DRY EASY 300 /.

Please note that the outer cover of the dehumidifier is made of metal. In the upper part of this cover during electric heating, its temperature can rise up to 65°C (at an air temperature of 35°C). It is therefore forbidden to touch the metal cover at the top of the dehumidifier during operation of the heater. It is also forbidden for children to play with or with the dehumidifier. Please note that children should be supervised by an adult at all times in the room where the dehumidifier is installed.

El. connection of hot water heating element		
El. heating element – input	El. cable	El. insulation
2,5 kW	CYSY 2 x 2,5 mm ²	16 A

The device can be equipped with an IP44 power cable. Use an IP44 socket. A socket with a lower degree of protection than IP44 does not guarantee the protection of the dehumidifier.

When using an IP44 power cord and outlet:

- Do not place the plug and socket in humid places or in places with leaking or dripping water.
- Do not place any objects on the cable, do not use the cable for any purpose other than to power the device.
- Place the cable away from other appliances such as radiators, motors, rotors, etc.
- Do not use a dehumidifier if the cord shows signs of damage.
- Always observe the electrical requirements for installation / e.g. breaker.
- Children and unauthorized persons must not manipulate the cable or plug.

5.7 Air filter – on demand

Your dehumidifier can be equipped with an air filter on request. The air filter traps dust and other mechanical particles and prevents them from entering the fins of aluminum heat exchangers. Although the air filter contributes to the cleanliness of the dehumidifier, it does not have the function of an antibacterial HEPA filter.

The operation of your dehumidifier is highly dependent on the continuous supply of air from the environment. It is therefore important to keep the air filter clean. Please read the simple steps below to clean the filter. If the filter is clogged with dirt, it creates a barrier to air supply. The manufacturer recommends cleaning at least once a month. The manufacturer, distributor and dealer are not

responsible for damage or malfunction of the device resulting from insufficient cleaning of the air filter.

When replacing the filter, it is necessary to disconnect the dehumidifier from the el. and the device must be switched off.



1. Remove the dehumidifier cover. Pay close attention to the controller connectors, such as cables and antennas.

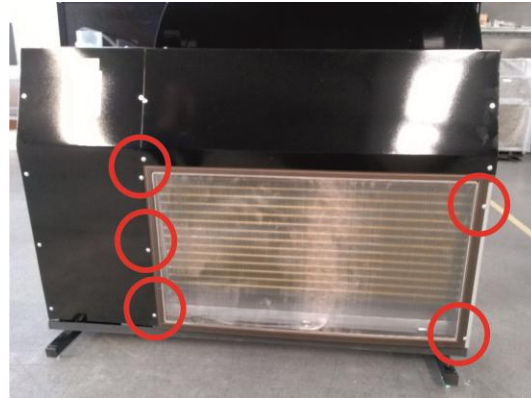

2. Unscrew the 2 screws on the right side and easily loosen the 3 screws on the left side.



3. Pull out the filter and slide it to the bottom left.

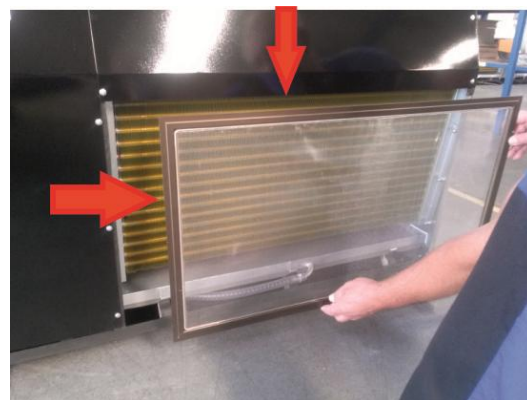

4. Remove the filter from the dehumidifier.

5. Clean the filter with a vacuum cleaner or rinse with clean warm water. If necessary, you can use a mild detergent. Allow the cleaned filter to dry. Do not expose the filter to the sun.

6. Then install the filter according to the above steps in reverse order.

A. Electrical installation FRESH AIR INTAKE WITH AUTOMATIC CONTROL OF BLINDS

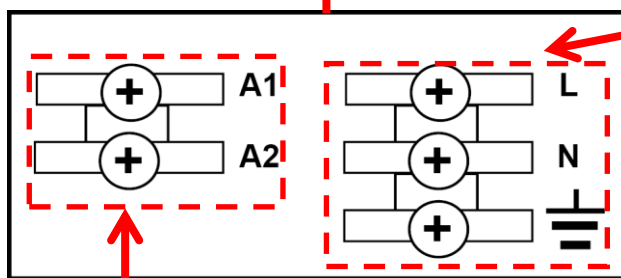
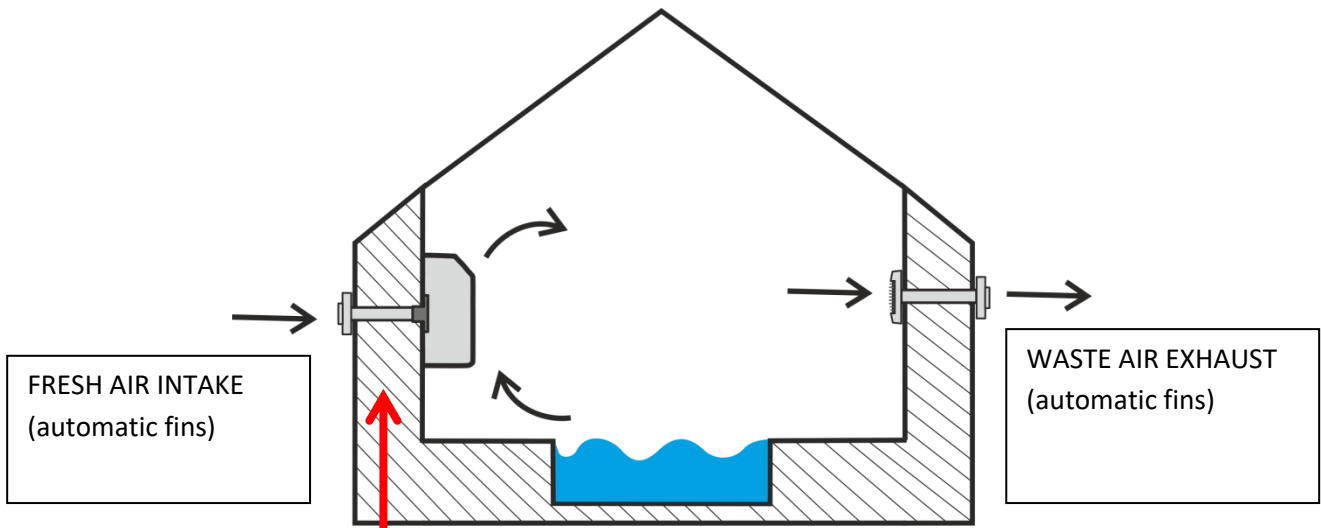

MAIN POWER SUPPLY OF DEHUMIDIFIER
230V/50Hz/1f
3x 2.5mm² CYSY
breaker
16A(DRY800)/20A
(DRY1200) type C
circuit breaker 30mA

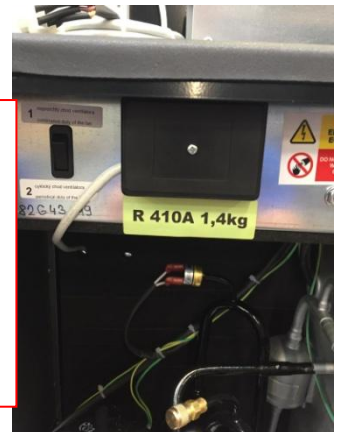

PERIPHERAL CONTROL
230V/50Hz/1f
3x 0.5-1mm² CYSY
Separate contactor with separate phase

The contactor is supplied by the customer (fan and electric blinds are part of the delivery if ordered)

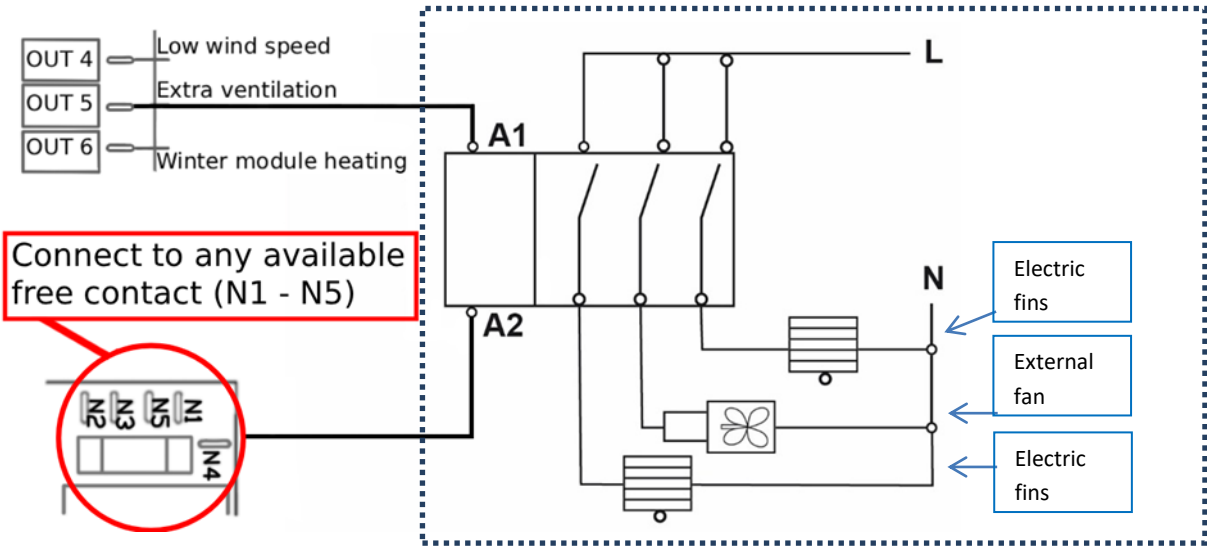

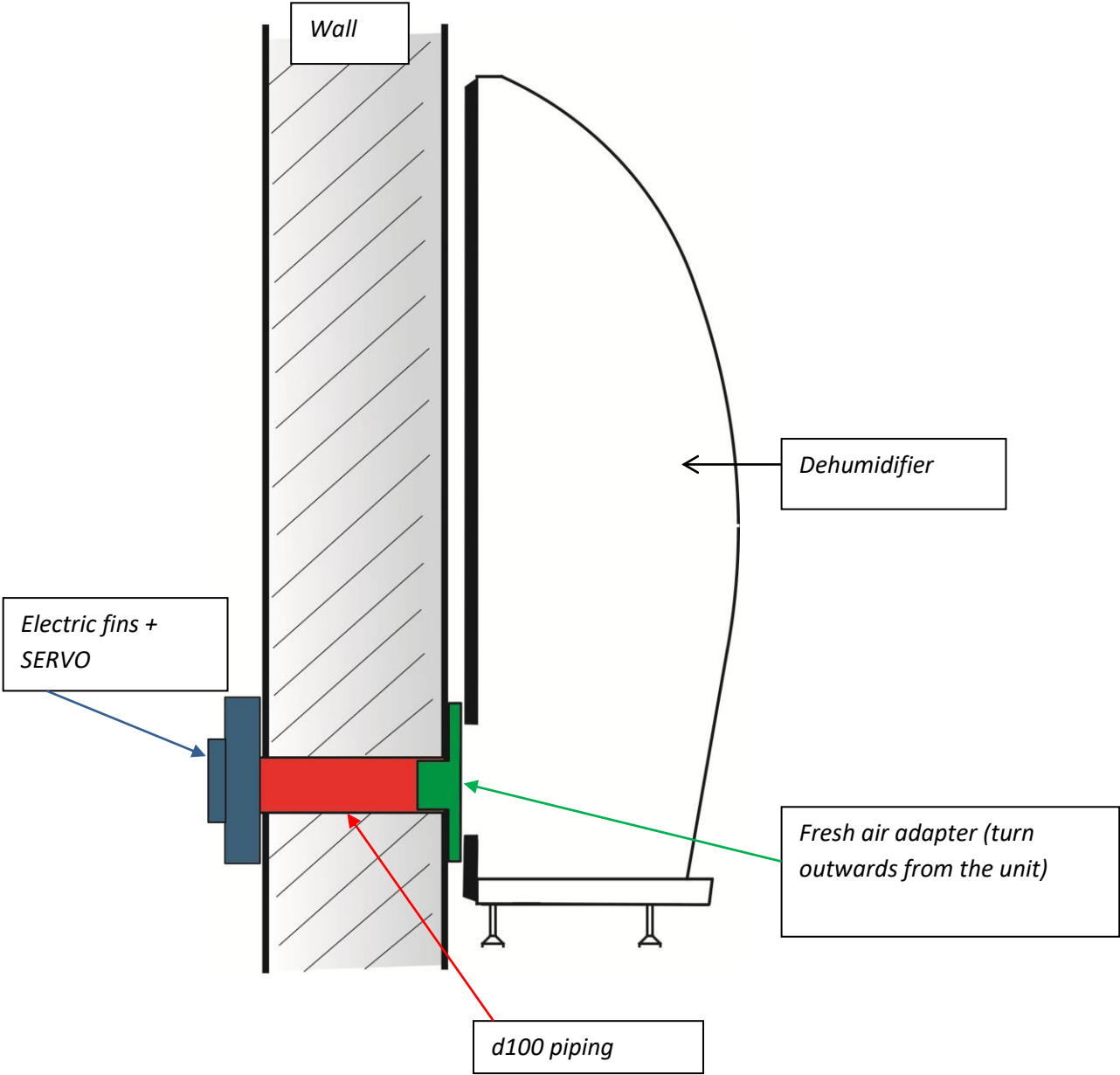

10 TECHNICAL DATA

6.1 Technical data chart*

Data	Unit	DRY 800 METAL	DRY 1200 METAL
For swimming pool with a max. water surface of:	m ²	60-90	90-120
Dehumidification performance at 30°C and 60% RV	l/24h	90	120
Dehumidification performance at 30°C and 70% RV	l/24h	112	150
Dehumidification performance at 30°C and 80% RV	l/24h	136	181
Operating temperature - defrost set	°C	22-35	22-35
Operating temperature - Thermostatic expansion valve (TEV)	°C	15-35	15-35
Operating temperature - defrost set + TEV	°C	35-42	35-42
Operating humidity + range	% RV	20-100	20-100
Air flow	m ³ /h	1100	1200
Noise (at 1m distance)	dB (A)	46	46
Heating output	W	5100	5250
El. input	W	1700	2400
Power supply	V/Hz/f	230/50/1	230/50/1
Operating/starting current	A	8/50	12/60
El. insulation – type C	A	16	20
Power cord	mm ²	CYSY 3C x 2,5	CYSY 3C x 2,5
Condensing pipe - outer diameter	mm	d 20	d 20
Net dimensions (width x height x depth)	mm	1250 x 950 x 310	1250 x 950 x 310
Net weight	kg	96	100
Refrigerant quantity - R 410 A	kg	1,45; 3,02t CO ₂ ekv.	1,65; 3,45 t CO ₂ ekv.
Max. system pressure HP/LP	bar	35/14	35/17

* The manufacturer reserves the right to change the data without notice.

The refrigerant circuit is filled with R410A refrigerant, which is a two-component refrigerant (R32 / R125). These components are in accordance with Act No. 286/2009 Coll. in conjunction with Regulation (EC) No 1049/2001 of the European Parliament and of the Council 842/2006 considered as fluorinated greenhouse gases. The installations contain fluorinated greenhouse gases covered by the Kyoto Protocol:

**R410A with global warming potential (GWP) 2088:
(R-32/125 50/50)**

These data are for information only. The exact amount of refrigerant in the appliance is indicated on the rating plate (located at the back of the appliance in the upper right corner).

EL. CONNECTION SCHEME DRY 800, 1200 – BASIC PCB CONNECTION

DRY 800, 1200 (2026)

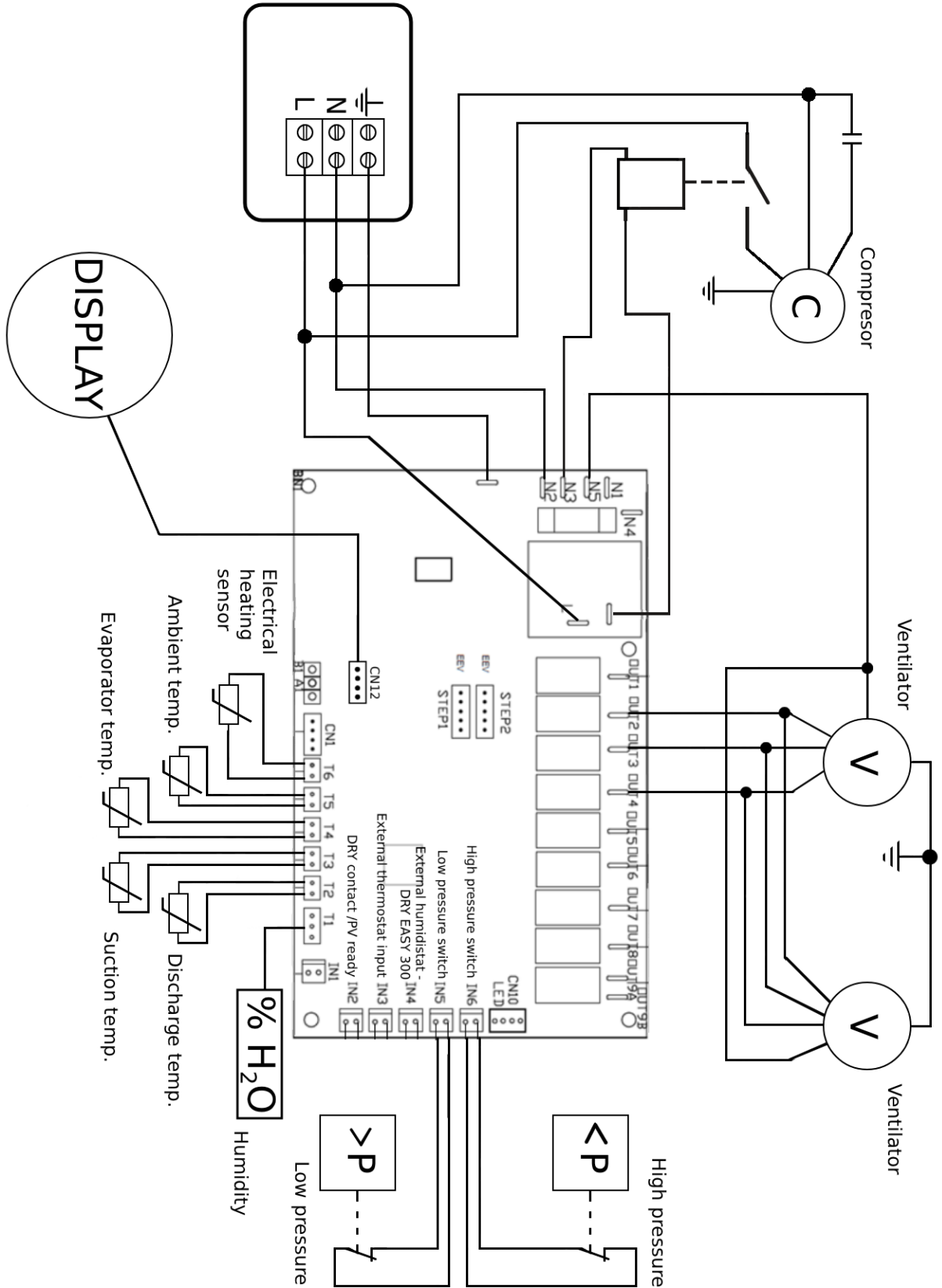

Schemes for older units

21.06.2021

DRY 800.1 (OMRON)

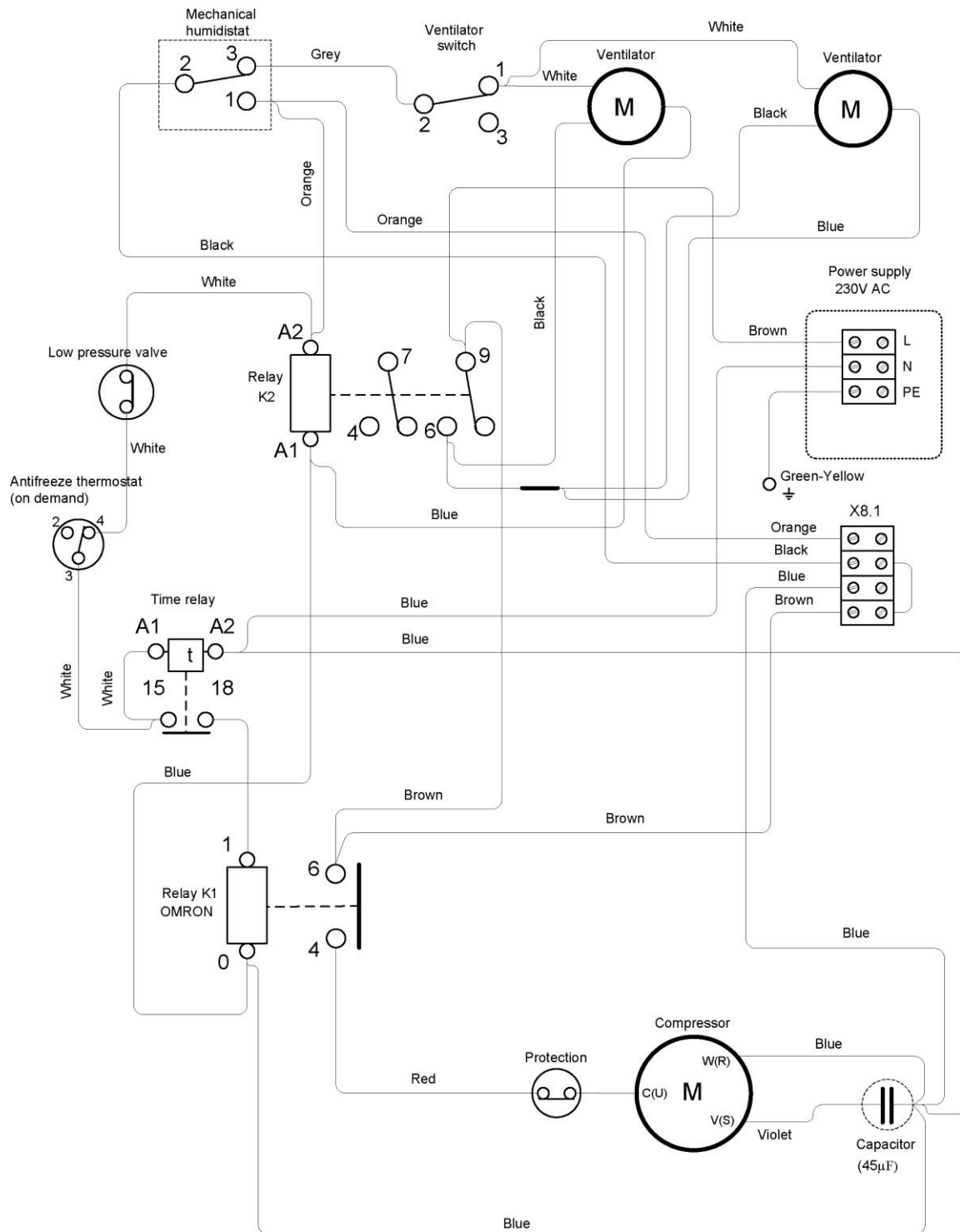

DRY 800.2

21.06.2021

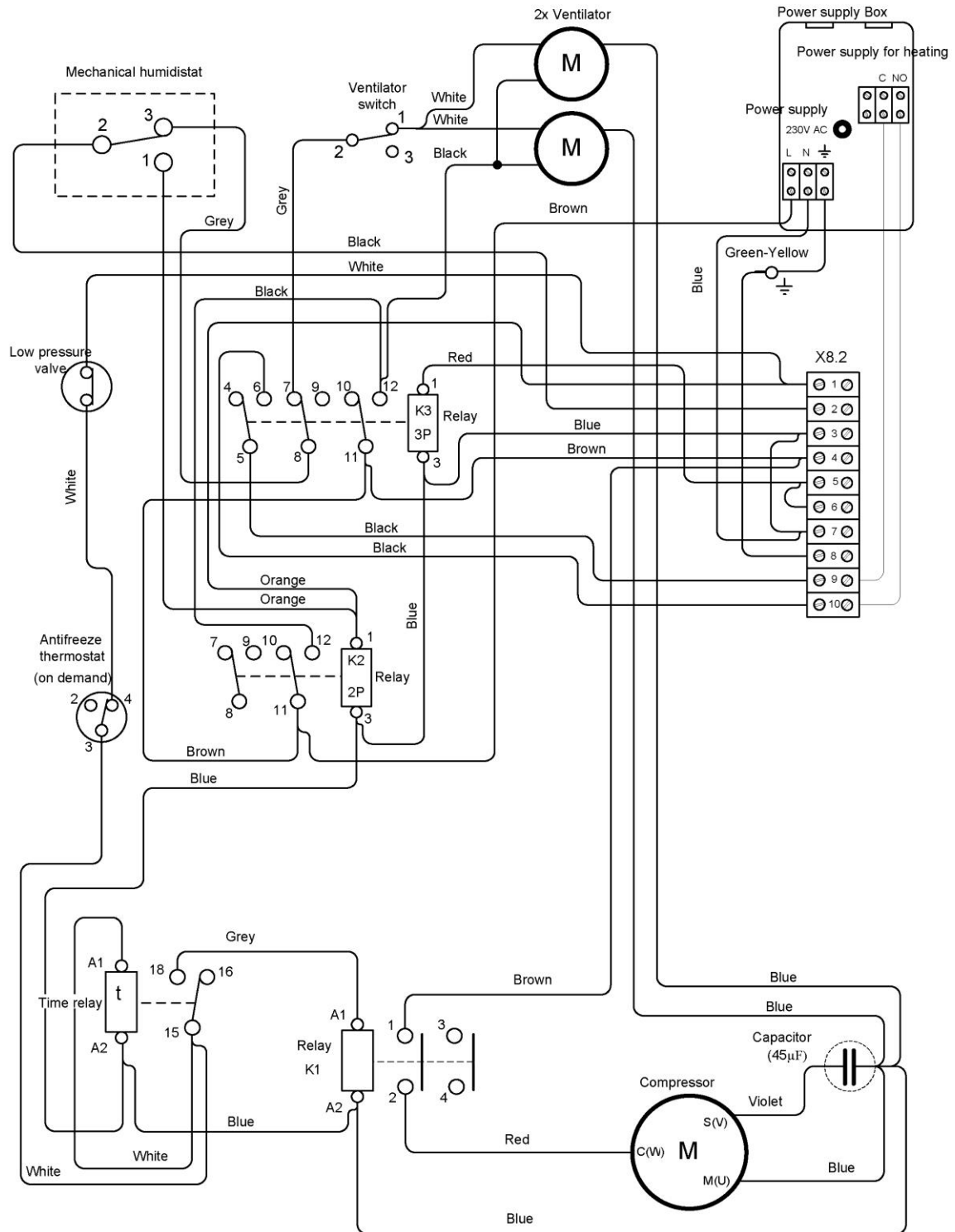

DRY 800.2 + El. heating 2000W

23.11.2021

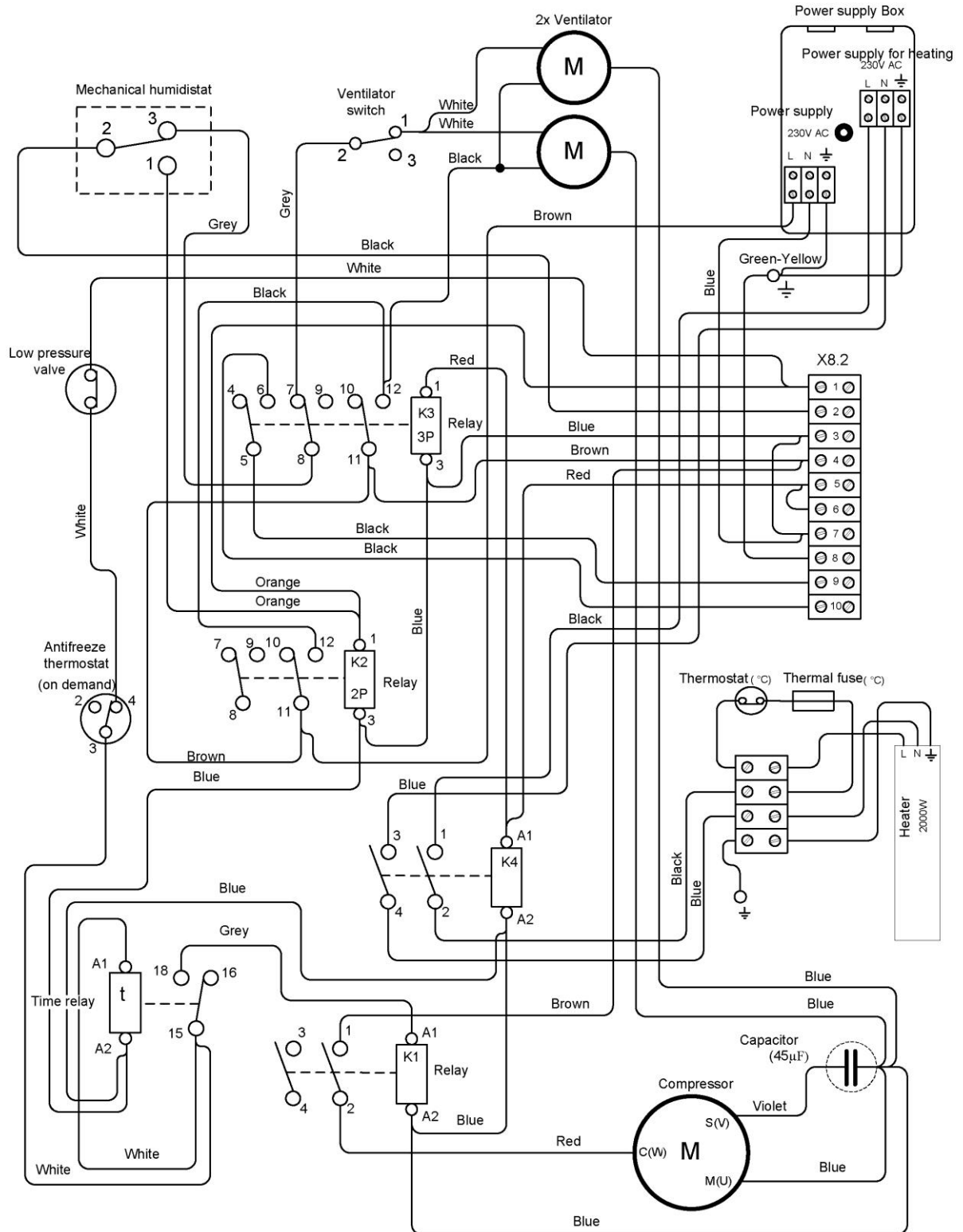

10.1.1 EL. CONNECTION SCHEME DRY 800 – ADVANCED CONNECTION

DRY 800.1 - Connection of terminal block X8.1 and humidity / thermostats 1401F, EASY 300, EBERLE

DRY 500.1, DRY 800.1, DRY 1200.1

30.8.2021

X5.1, X8.1, X12.1 DSFOX, EASY 300, EBERLE

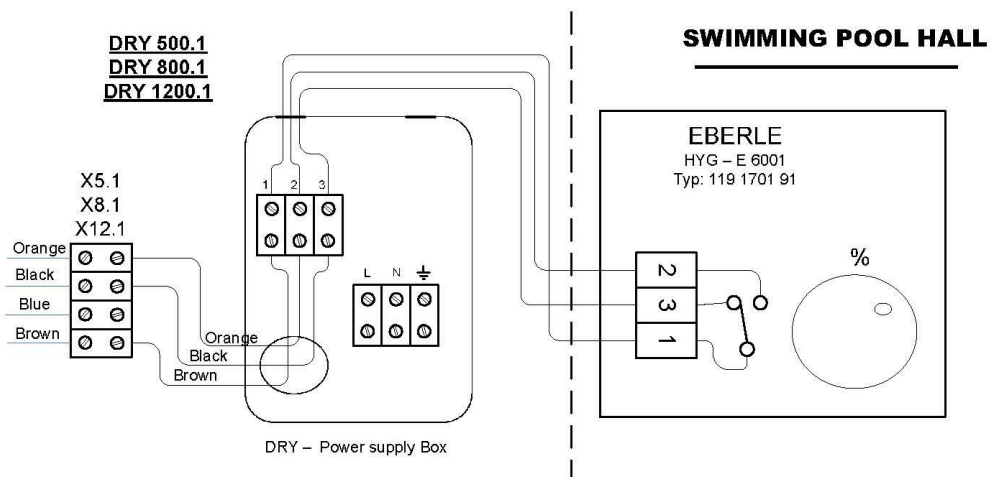
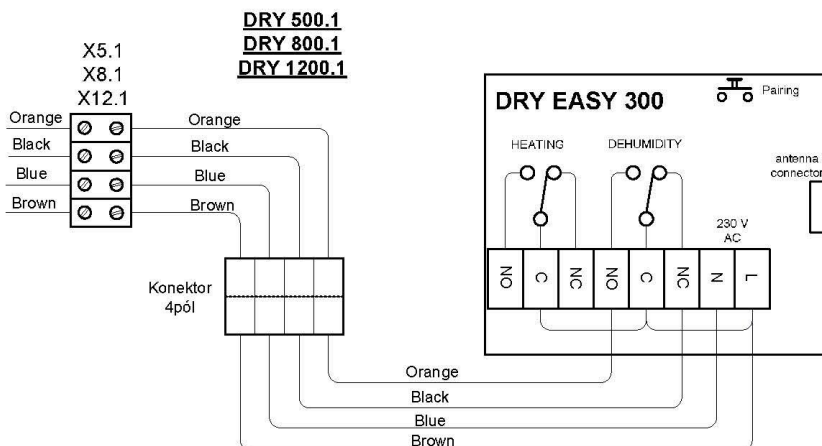
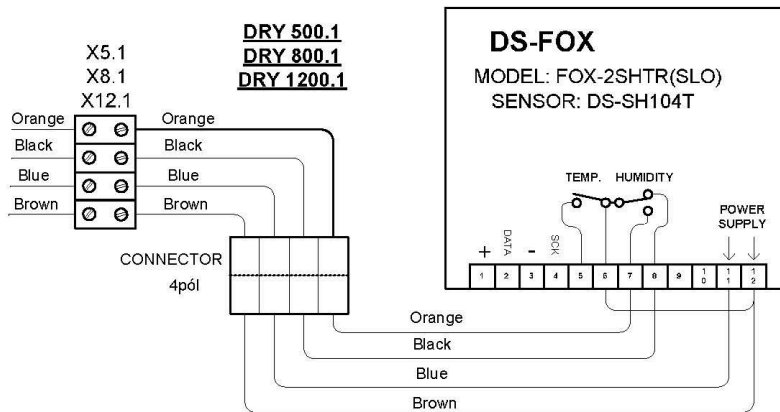

DRY 800.2 - Connection of terminal block X8.2 and humidistat with thermostat, voltage-free heating contact and solenoid valve

**DRY 500.2, 800.2, 1200.2 - X5.2, X8.2, X12.2
DS FOX**

30.8.2021

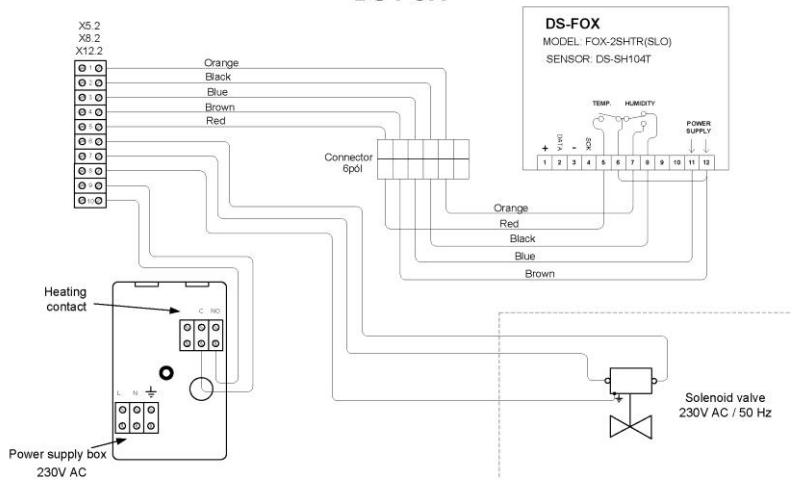

**DRY 500.2, 800.2, 1200.2 - X5.2, X8.2, X12.2
EASY 300**

30.8.2021

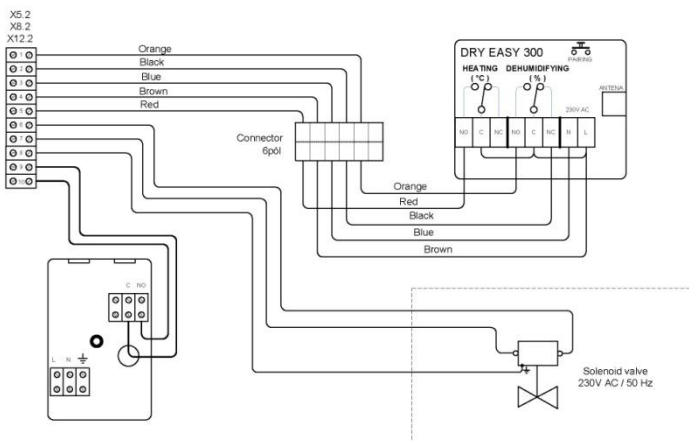

**DRY 500.2, 800.2, 1200.2 - X5.2, X8.2, X12.2
HYGROSTAT -TERMOSTAT EBERLE HYG-E7001**

3.9.2021

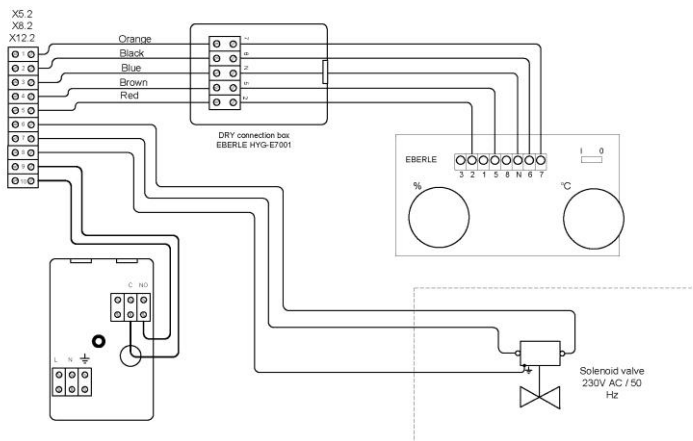

10.1.2 EL. CONNECTION SCHEME DRY 1200 – BASIC CONNECTION DRY 1200.1

21.06.2021

DRY 1200.1

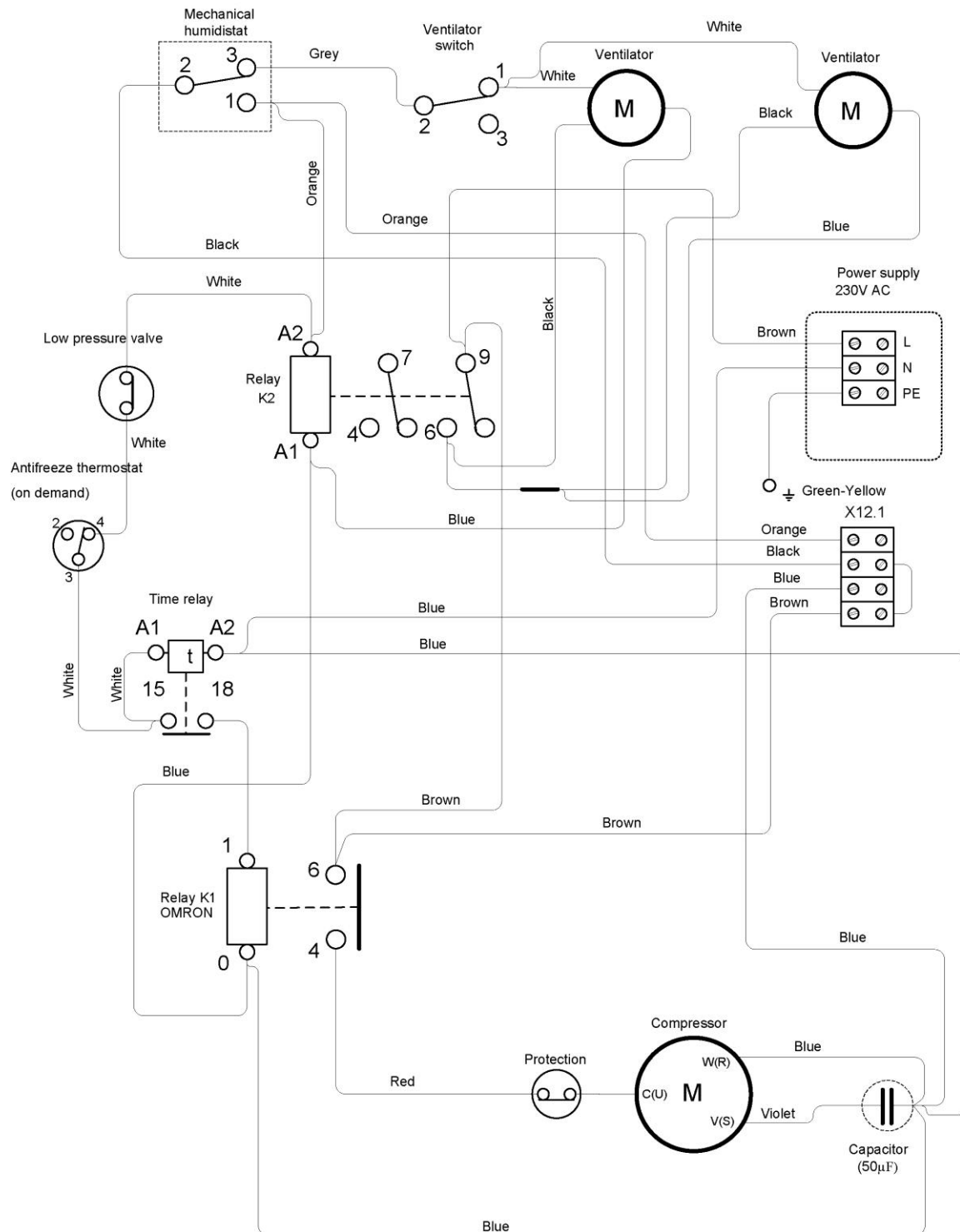

DRY 1200.2 (2021)

21.06.2021

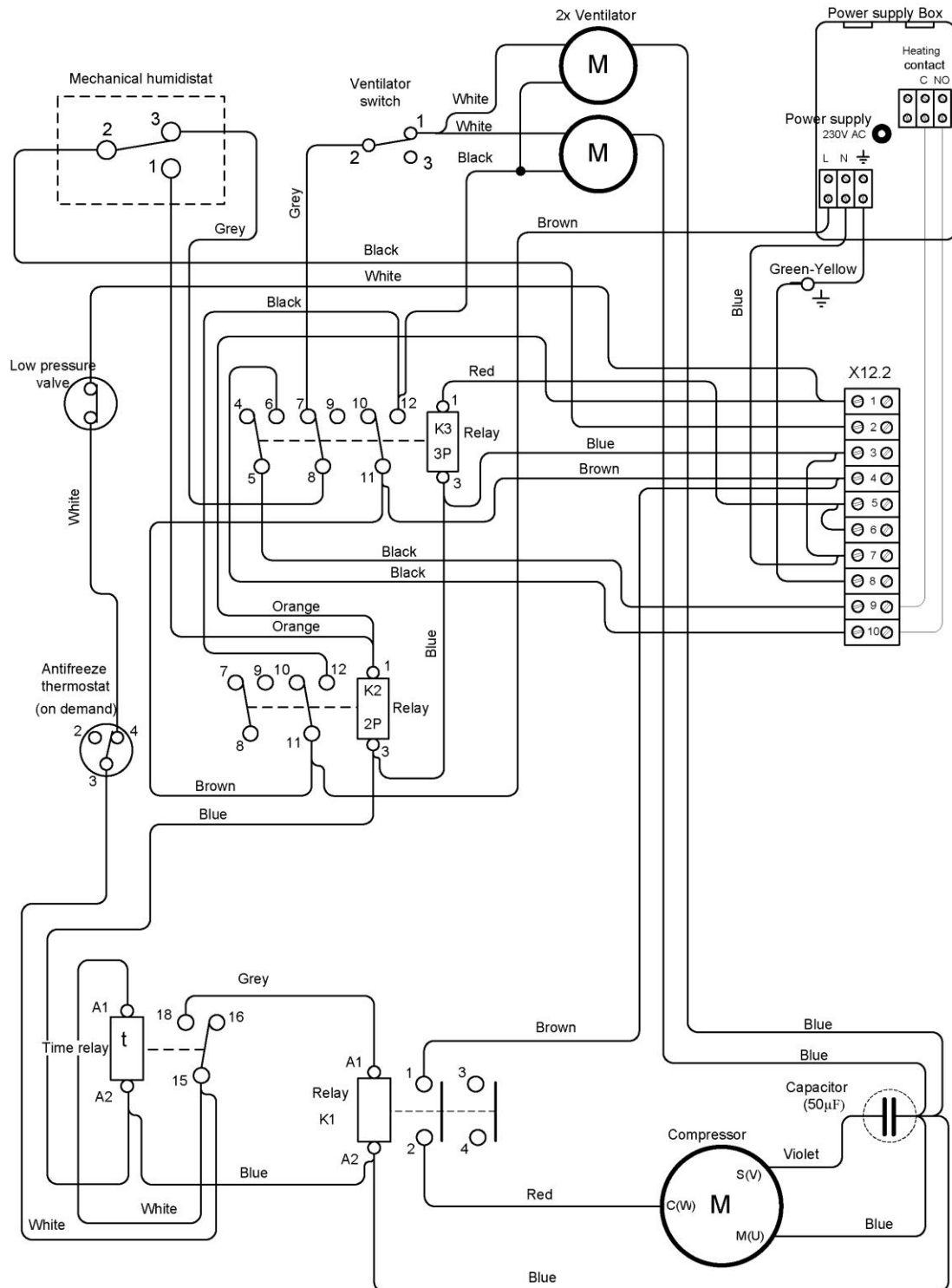

DRY 1200.2 + EI. heating 2000W

23.11.2021

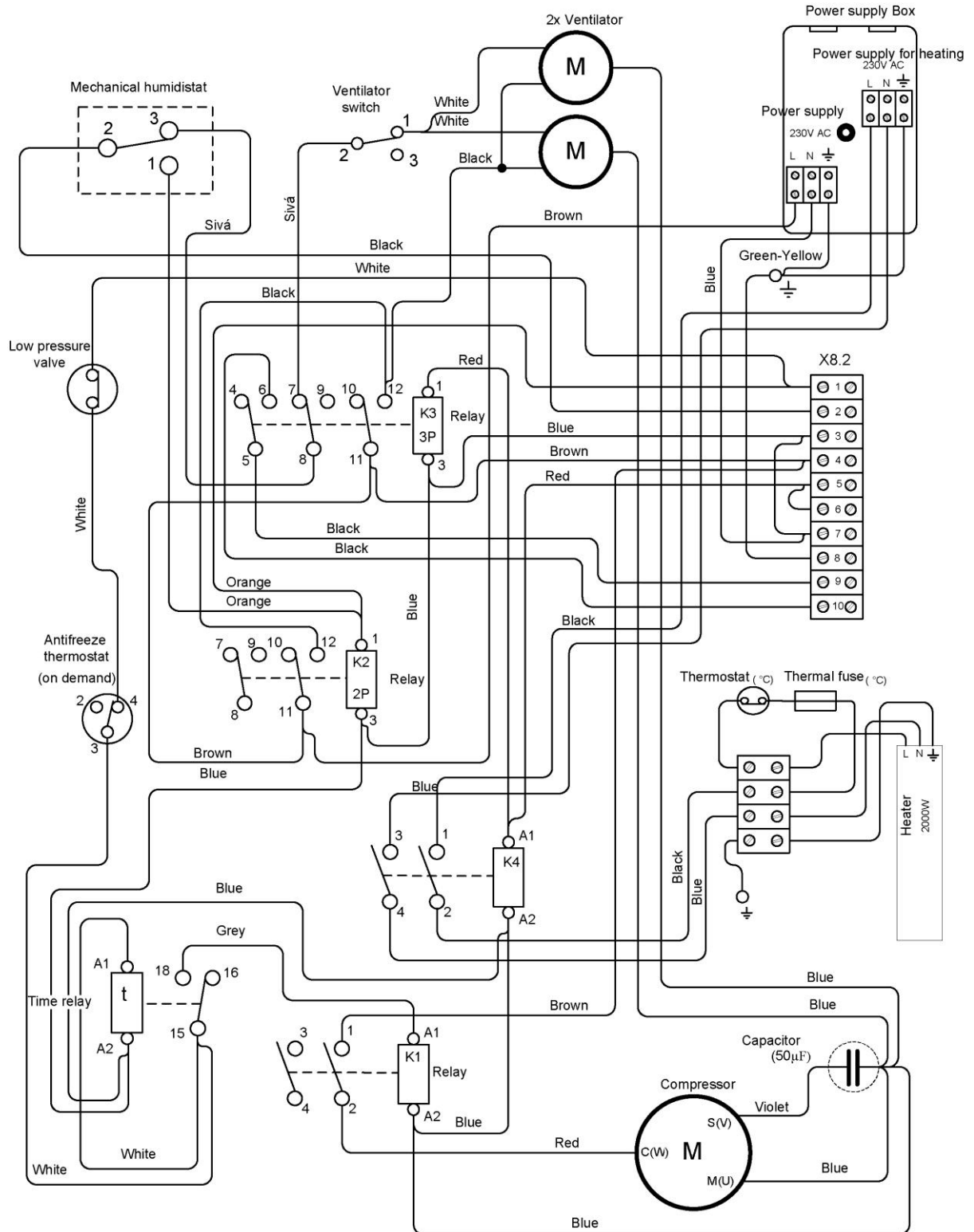

DRY 1200.1 - Connection of terminal block X12.1 and humidity / thermostats 1401F, EASY 300, EBERLE

DRY 500.1, DRY 800.1, DRY 1200.1

30.8.2021

X5.1, X8.1, X12.1 DSFOX, EASY 300, EBERLE

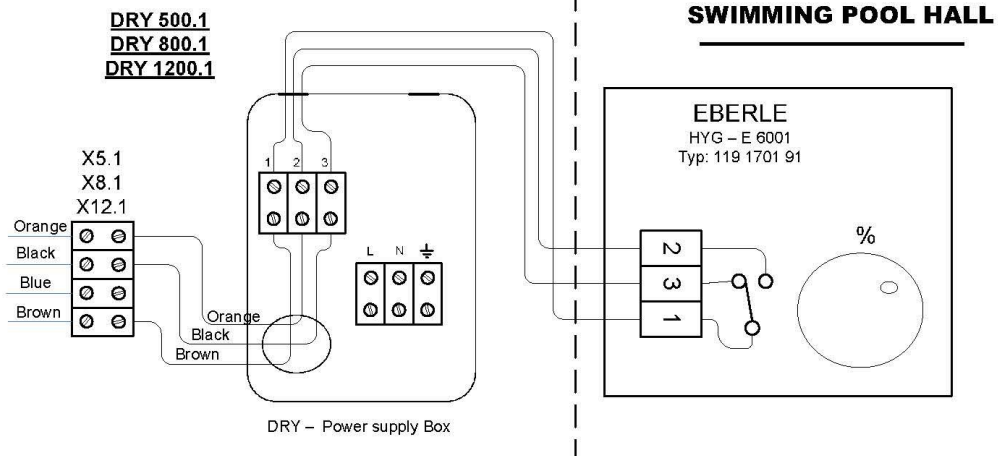
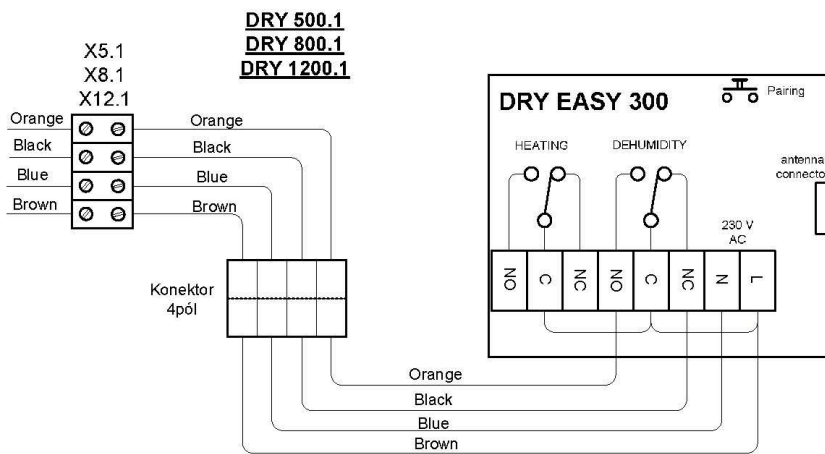
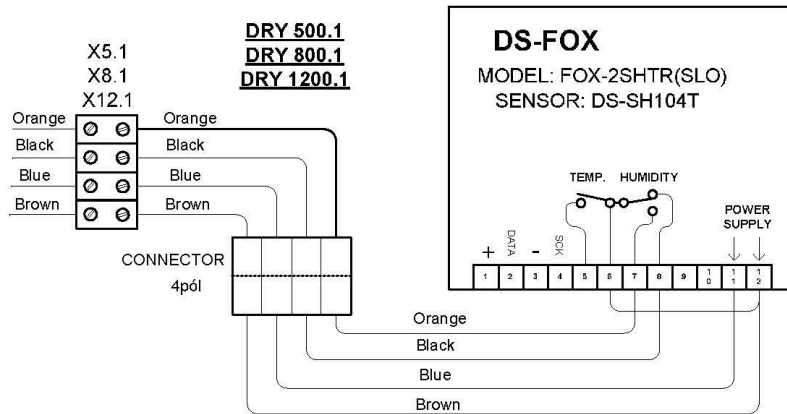

DRY 1200.2 - Connection of terminal block X12.2 and humidistat with thermostat, voltage-free heating contact and solenoid valve

**DRY 500.2, 800.2, 1200.2 - X5.2, X8.2, X12.2
DS FOX**

30.8.2021

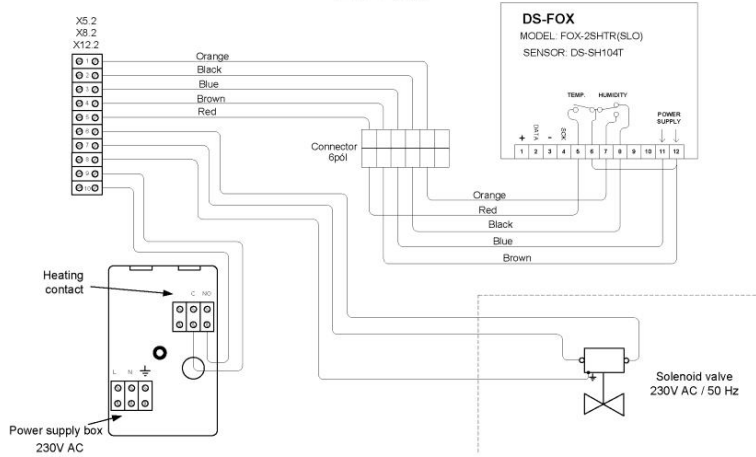

**DRY 500.2, 800.2, 1200.2 - X5.2, X8.2, X12.2
EASY 300**

30.8.2021

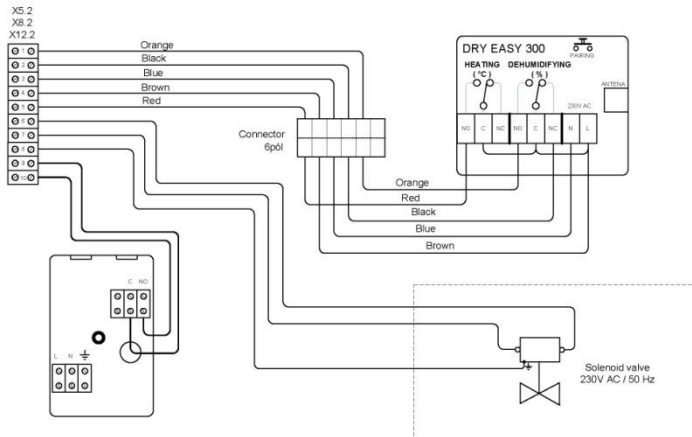

**DRY 500.2, 800.2, 1200.2 - X5.2, X8.2, X12.2
HYGROSTAT -TERMOSTAT EBERLE HYG-E7001**

3.9.2021

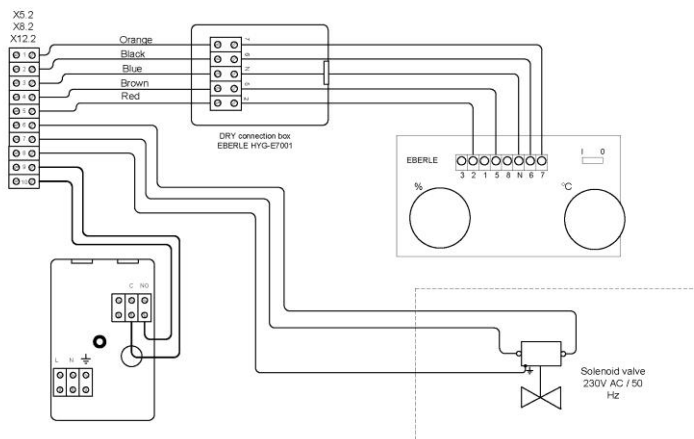

11 SUMMER SHUTDOWN

Users of indoor pools take the opportunity to shut down the dehumidifier for the summer. This is mainly due to favorable weather conditions during the summer - dry and warm weather. In this case, the natural air exchange regulates the humidity in the pool hall for several weeks/months of the year. However, with rapid weather changes (such as during rainy days), it can result in high humidity in your pool hall.

In this case, make sure that:

1. The dehumidifier circuit breaker is switched off (ie the dehumidifier has no power supply).
2. The dehumidifier cleans the air filter of dust or other contaminants that could settle and harden during downtime and be more difficult to remove later.
3. The dehumidifier is dried; the condensing tray does not contain water.
4. Make sure that the air inlet and outlet areas on the dehumidifier are adequately covered and protected from chlorine or other chemicals, especially the fan bearings. Failure to do so may result in bearing corrosion and damage to the dehumidifier.
5. Even during shutdown, we recommend releasing the dehumidifier at least once a month to prevent the fan grease from solidifying, after a few months the fan would not have to start at all.
6. **The manufacturer points out that during decommissioning of the dehumidifier; the humidity is not regulated in any way by the device and the device does not provide any drying function.**
7. **Make sure that the dehumidifier cannot be switched on when it is covered. This could cause the device to overheat and be damaged.**

7.1 Troubleshooting – save time and money

Error	Case / Description	Solution
Device does not work at all	Breaker out	Turn on the breaker
Device does not work at all	Circuit breaker out	Turn on the circuit breaker
Device does not work at all	Power supplier energy failure	Wait for the power to recover
Device doesn't dehumidify	The fan does not run or does but the dehumidifier does not dehumidify	Check the set value of the required humidity. If it is higher than the set value, set it to a lower value
Device doesn't dehumidify	4 min. after the fan has started, the compressor will also start but will switch off immediately after a few seconds	Check electronic components - compressor thermal fuse, switching relay, time relay, pressure switch
Device doesn't dehumidify	4 min. after the fan has started, the compressor will also start but only for a few minutes and then switch off	Check the refrigeration circuit - refrigerant may leak
The walls are wet	The device is dehumidifies but the walls are wet	Undersized dehumidification capacity. It needs to be supplemented with another dehumidifier.

7.2 Maintenance instructions

The device must be inspected and cleaned by a specialist at least once a year. This is essential to ensure the longevity and reliable operation of the equipment.

- Fixing the unit - visual inspection – is the unit OK? No cracks / damage / bends?
- Unit check - clean air inlet and outlet? No objects blocking air circulation?
- Air filter (if included) - cleaned air filter? Air filter inside?
- LPHW - connection is OK? No leakage? Is there hot water inside when turned on?
- Condensate drain - visual inspection - is it drained correctly? Does it clean from dust? No vibrations? No leakage? No water stains on the ceiling or wall?
- Electrical connection - visual inspection - is the connection OK? No burns? No damage? No odour?

7.3 Cleaning by superchloring

Although MICROWELL DRY dehumidifiers are made of the most durable materials, chlorine is a very aggressive substance. The typical chlorine content in the pool air is up to 1.0 ppm. MICROWELL DRY dehumidifiers are equipped with a special protection against chlorine, but they cannot protect the unit in an environment with a chlorine content higher than 3.0 ppm. When cleaning the pool area with superchlorination, it must be borne in mind that the DRY dehumidifier must be switched off, as the chlorine concentration during superchlorination reaches up to 24 ppm. The unit must be switched off and ideally covered. Restore unit function after superchlorination and room ventilation.

7.4 Operation during construction

When you run the device in a pool that is still under construction, run it for a minimum of time. Do not turn on the device for more than a few minutes. Dust present in the air can collect on the heat exchanger and reduce the water collection capacity. Perform an initial test and demonstration, but leave the unit turned off and covered until the pool is completely constructed. **Make sure that the dehumidifier cannot be switched on when it is covered. This condition would overheat the device and damage it.**

7.5 microLIGHT+

The DRY300 / 400/500 can be equipped with the unique Microwell microLIGHT + system. It is a built-in LED strip that is located inside the unit. microLIGHT + will signal the current color humidity level.

BLUE - low humidity
GREEN - ideal humidity
YELLOW - humidity rises above a critical level
ORANGE - humidity rises above a critical level
RED - humidity too high

The ideal humidity in swimming pools is between 55% and 65% relative humidity. Humidity above 70% is too high and constantly deteriorates the materials in the pool and creates a favorable environment for bacteria. Moisture below 40% dries the mucosal tissue and is usually considered "dry". With microLIGHT+ you don't have to understand any image. **If it's green, everything's fine. If it's red, you have a problem.**

microLIGHT+ will also signal if your humidity is rising. For example, if you have a covered pool and the humidity is fine, you will see a green light. When you uncover it and start swimming, microLIGHT+ may turn yellow, orange or red after a while. This indicates that your humidity is rising. Don't be disturbed, it's normal. When you stop using the pool and cover it, the dehumidifier should dry the air in a maximum of a few hours (depending on the actual size of the pool) and the color should return to normal, i. j. Green. If red persists for more than 1 day, check the device.

12 WARRANTY CONDITIONS

The device is covered by a warranty period of 2 years. The warranty period can be extended by your reseller. Please contact your reseller or distributor if the warranty should be applied to the dehumidifier.

Use the following Microwell disclaimer under warranty. No claim will be accepted if:

1. The dehumidifier was used incorrectly, other than as described in this manual or in violation of this user manual, resp. against the safety precautions listed in this manual.
2. The dehumidifier has been installed incorrectly, other than as described in these operating instructions or in violation of this user manual.
3. The dehumidifier has been put into operation by an unauthorized person.
4. The air flow in the dehumidifier is outside the defined limits.
5. The device has been subjected to mechanical damage / forcible or any unauthorized action has been taken on the design of the unit - welding, soldering or mechanical damage by scratches, mixtures, compression, pipe rupture, etc. Without mechanical damage, the complaint is accepted, unless a written complaint is made with the equipment supplied by the carrier.
6. The chemical conditions in the pool were not within the defined limits (see the table of permitted chemical values below).
7. The dehumidifier has been exposed to frost or high temperatures outside the operating temperature range.
8. Power supply. voltage insufficient or otherwise incorrect.
9. Switching the dehumidifier on/off by interrupting the electrical power supply during operation. (Device remains in standby by setting the humidity on the hygostat, e.g. set to 90%).



When requesting warranty, contact your distributor and have the device identifiers ready, i.e. model, serial number and date of purchase. Please describe the genesis of the failure. This will speed up the complaint handling process.

Acidity / pH level:	pH	7,4 +/- 0,4
Total alkalinity, CaCO ₃	ppm	80-120
Total hardness, CaCo ₃	ppm	100-300
Total dissolved dry matter	ppm	max. 3000
Maximum salt content (standard dehumidifier)	wt/wt	0.3% (3,000 ppm, 3 kg of salt per 1 m ³ of water)
Maximum salt content (dehumidifier with SALT+/SULPHUR+ treatment)	wt/wt	3% (30,000 ppm, 30 kg of salt per 1 m ³ of water)
Free chlorine range	ppm	1,0-3,0
Superchlorination	ppm	max. 30 ppm/max. 24 hours
Bromine	ppm	2-3
Baquacil	ppm	25-50
Ozone	ppm	0,8-1,0
Maximum copper content	ppm	max. 2
Aquamatic lone cleaner	ppm	max. 2
Tarn clean cleaner	ppm	max. 2
Sherwood cleaner	ppm	max. 2

Tab.: Permitted chemical value

TRANSPORTATION



The dehumidifier must only be transported in the original packaging in an upright position. When transporting, secure the dehumidifier against tipping over and falling. Never place the dehumidifier on its side! There is a risk of serious damage to the compressor! Damage during transport is never covered by the warranty! If you receive the shipment, check the integrity of the packaging and document any defects.



TECHNICKÝ SKÚŠOBNÝ ÚSTAV PIEŠŤANY, š.p.
Certifikačný orgán certifikujúci výroby
Product Certification Body
Krajinská cesta 2929/9, 921 01 Piešťany
Slovenská republika/Slovak Republic



CERTIFIKÁT ZHODY CONFORMITY CERTIFICATE

č./No. 231299156

Výrobca/Manufacturer: **MICROWELL, spol. s r.o**
SNP 2018/42
927 00 Šaľa, Slovenská republika / Slovak Republic

Výrobok/Product: **Bazénový odvlhčovač MICROWELL**
Swimming pool dehumidifier MICROWELL

Typ/Type: **DRY 500 WAVE**

Odvođené typy / Derived types: **uvedené na druhej strane / see the next page**

Tento certifikát zhody potvrdzuje, že výrobok spĺňa základné požiadavky na bezpečnosť podľa nasledovných smerníc ES/EÚ nového prístupu v ich platnom znení:
This conformity certificate confirms the conformity of the product with essential safety requirements of the following EC/EU New Approach Directives as amended:

2014/35/EÚ	Smernica o LVD	2014/35/EU	LVD Directive
2014/30/EÚ	Smernica o EMC	2014/30/EU	EMC Directive

Harmonizované normy použité pre posúdenie zhody:
Harmonized standards used for the conformity assessment:

EN 60335-1:2012/AC:2014/A11:2014/A13:2017/A1:2019/A14:2019/A2:2019/A15:2021
EN 60335-2-40:2003/A11:2004/A12:2005/AC:2006/A1:2006/A2:2009/AC:2010/A13:2012/AC:2013
EN 61000-3-3:2013

Iné normy použité pre posúdenie zhody:
Other standards used for conformity assessment:

EN IEC 55014-1:2021
EN IEC 55014-2:2021
EN IEC 61000-3-2:2019/A1:2021
EN 61000-3-3:2013/A1:2019/A2:2021/AC:2022-01

Certifikát je vydaný na základe skúšok vzorky typu výrobku. Výsledky sú uvedené v Správe o posúdení zhody č. 230500076 zo dňa 27.04.2023

The certificate has been issued on the basis of the tests of the product type sample. The results are recorded in the Conformity assessment report No. 230500076 dated 27.04.2023



označenie môže byť použité iba v prípade posúdenia zhody so všetkými príslušnými smernicami ES/EÚ
mark can be used only in the case of conformity assessment according to all relevant EC/EU Directives

Dátum vydania/Issue date: 28.04.2023
Platnosť do/Expiry date: 27.04.2026
Vydanie /Issue: 1



Ing. Dušan HANKO
vedúci certifikačného orgánu
certifikujúceho výrobky
Head of Product Certification Body

Odvozené typy / Derived types:

DRY 300, DRY 400, DRY 500, DRY 800 a DRY 1200 v prevedení WAVE, METAL, SILVER a DUCT v kódovom označení:

DRY 300, DRY 400, DRY 500, DRY 800 and DRY 1200 in make of WAVE, METAL, SILVER a DUCT in code marking:

DRY300W	DRY300M	DRY300S	DRY300D
DRY400W	DRY400M	DRY400S	DRY400D
DRY500W	DRY500M	DRY500S	DRY500D
DRY800W	DRY800M	DRY300G	DRY800D
DRY1200W	DRY1200M	DRY400G	DRY1200D

Tento certifikát je vydaný za nasledujúcich podmienok:

1. Certifikát sa vzťahuje na typ výrobku a jeho varianty uvedené vo vyššie uvedenej správe o posúdení zhody.
2. Tento certifikát sa nevzťahuje na výrobný proces/vnútro podnikovú kontrolu.
3. Certifikát neznamená, že certifikačný orgán vykonáva dozor alebo kontrolu výroby.
4. Výrobca musí zabezpečiť zhodu následne vyrábaných výrobkov s certifikovaným typom.
5. Zmeny, ktoré majú vplyv na zhodu s certifikačnými požiadavkami môžu podmieniť ďalšiu platnosť certifikátu tým, že sa bude vyžadovať preukázanie zhody s podmienkami, za ktorých bol certifikát udelený, alebo dodatočným hodnotením.
6. Držiteľ tohto certifikátu musí dodržiavať podmienky uvedené vo Všeobecných pravidlách pre certifikáciu výrobkov, ktoré sú voľne dostupné na stránke www.tsu.sk

This certificate is issued under the following conditions:

1. The certificate applies to the product type and its variations specified in the above mentioned Conformity Assessment report.
2. The production process/factory production control is not covered by this certificate.
3. The certificate does not imply that the certification body has performed any surveillance or control of the production process.
4. The manufacturer shall ensure the conformity of subsequent production items with the certified type.
5. Changes that may have an impact on maintaining conformity with the certification requirements may require confirmation of the validity of the certificate by demonstrating compliance with the conditions under which the certificate was issued or by conducting an additional evaluation.
6. The holder of this certificate must keep the conditions specified in the General Rules for Product Certification, which are freely available at www.tsu.eu



Notes:

Notes:

Manufacturer:

MICROWELL, spol. s r.o.
Diakovská 7321, 927 01 Šaľa, Slovakia
tel.: +421/31/770 7082
e-mail: microwell@microwell.sk
www.microwell.eu

Distributor:

Made in: EUROPEAN UNION (SLOVAK REPUBLIC)
Country of Origin: EUROPEAN UNION (SLOVAK REPUBLIC)

